

# Intelligent (Unmanned) Material Construction Lifting Solution

-   
Intelligent Drive
-   
Human Detection
-   
HMI
-   
Smart Diagnostics
-   
Video Surveillance



## Product Profile

The S100 series drive for construction elevator boasts an advanced control system, integrating frequency conversion, intelligent drive, human detection, HMI, smart diagnostics, and video surveillance. This intelligent system streamlines wiring and installation, reducing maintenance and labor costs.

## System Topology

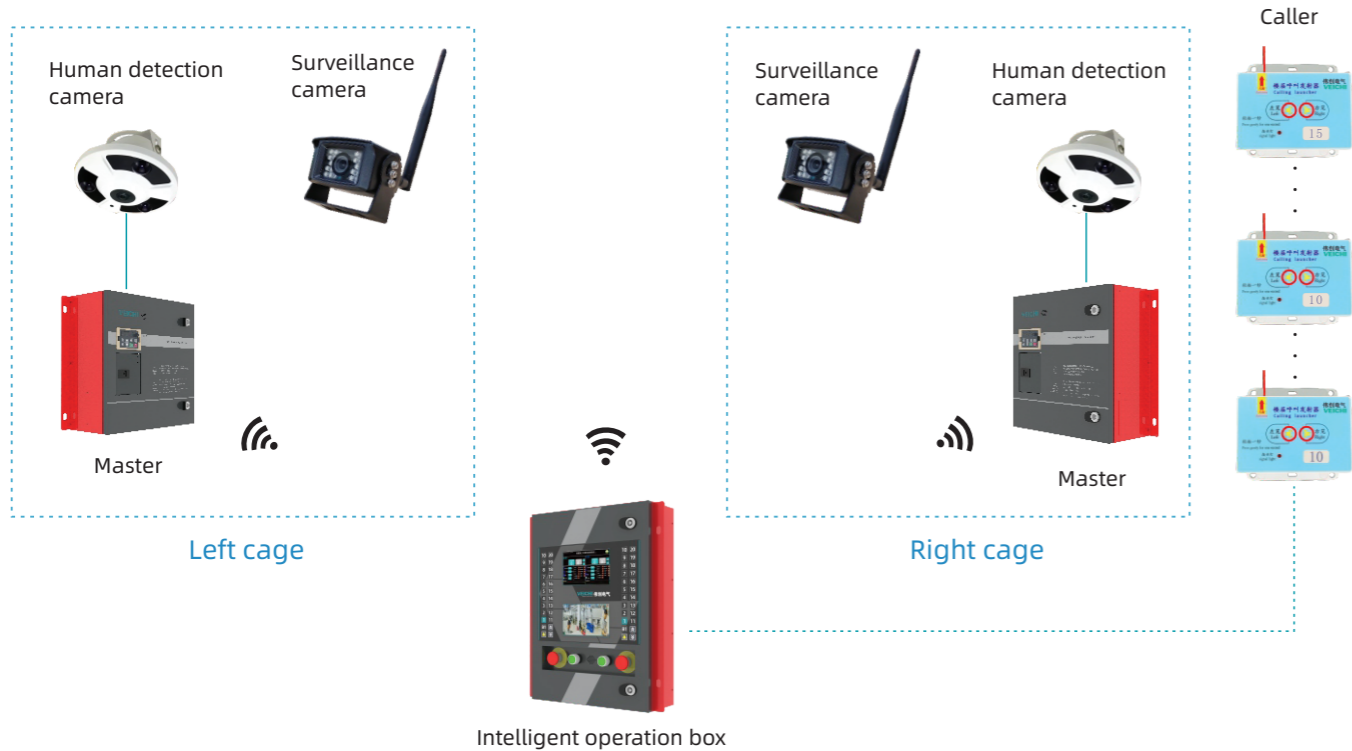

## Bottom Cage Operation Box

### Operation Box (S100-FJ-A0-01)

The intelligent box integrates control and power distribution features, efficiently saving space and simplifying installation.

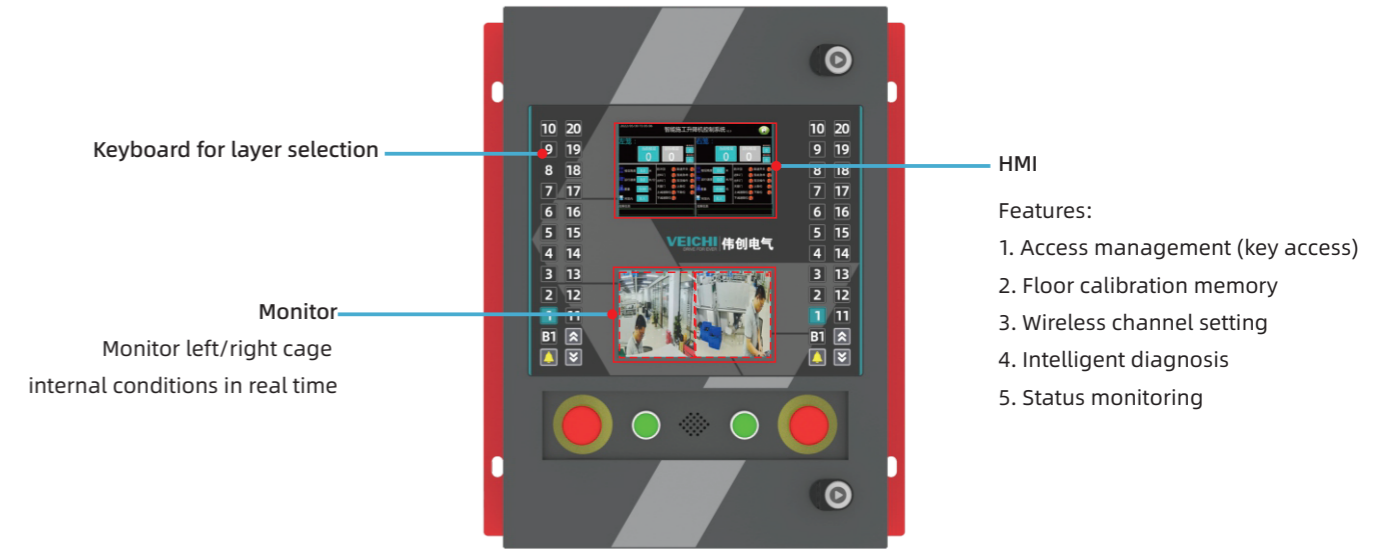

## Human Detection Camera

The cage camera detects riders, stopping the unmanned construction elevator and warning until they leave.

### Technical Specs:

- Resolution: 1080P
- Coverage: Cage interior
- Voice alarm
- 360° panoramic, no angle adjustment needed post-installation.

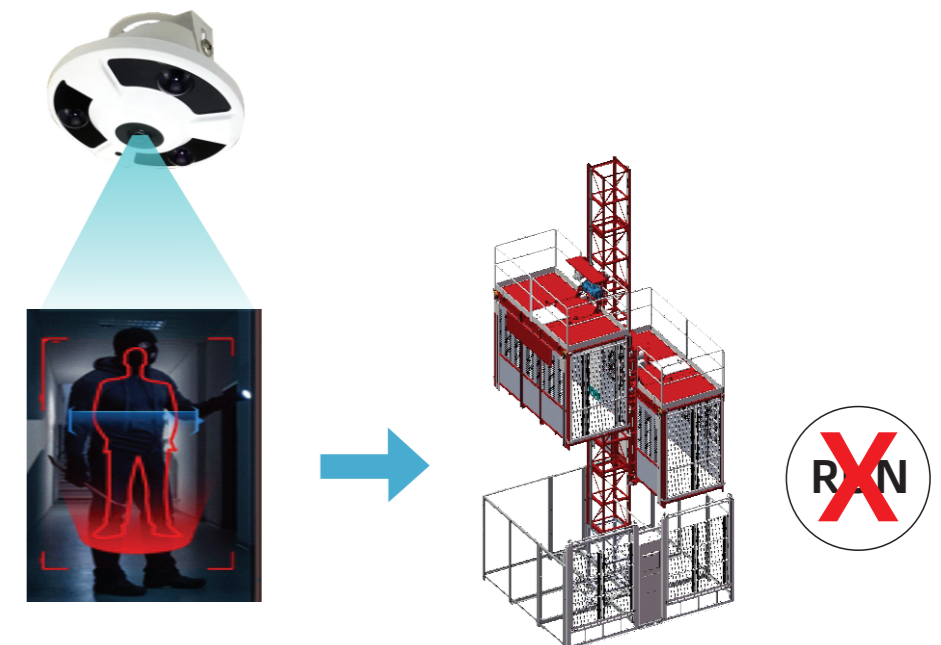

## Integrated Drive (S100-A0-018B)

The compact master is easy to install and maintain, available for wall or built-in mounting.

- 4-in-1: Variable frequency drive, logic and brake control, weighing function.
- Auto leveling with accuracy of  $\pm 2\text{mm}$ .
- GPS remote monitoring module (expansion).
- Stable performance with intelligent diagnostics.
- Power: 15kW~22kW.



## Installation Dimensions

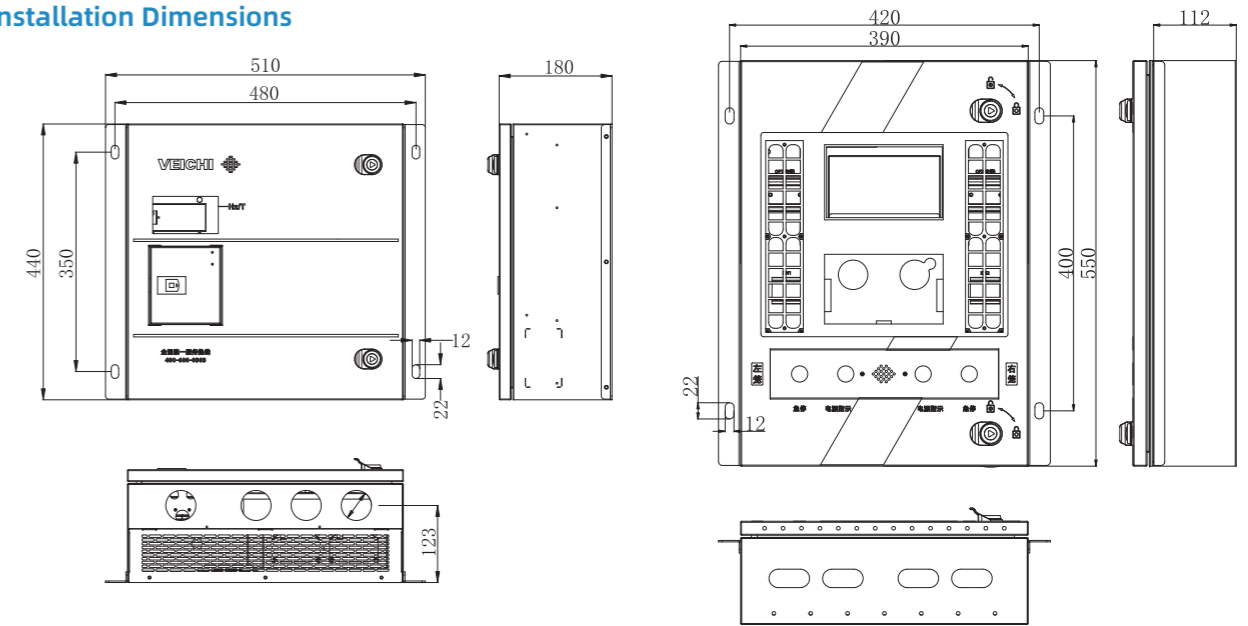

Master

Intelligent operation box

## High Power Wireless Transceiver Module

The wireless module facilitates two-way, fixed-frequency communication for both one-to-one motor and one-to-many drive data exchanges.

### Technical Specs:

- Multiple channels: Up to 128.
- Robust transmission: 500kbps~625kbps, with strong penetration and high anti-interference.
- Leading RF design: 30dbm high power, open range  $\geq 300\text{m}$ .
- Certified reliability: CE-certified for stable performance.



LoRa wireless module

## Keyboard for Selecting Layer

With multi-protection (dust-proof, water-proof), its service life is up to  $10^6$  presses.

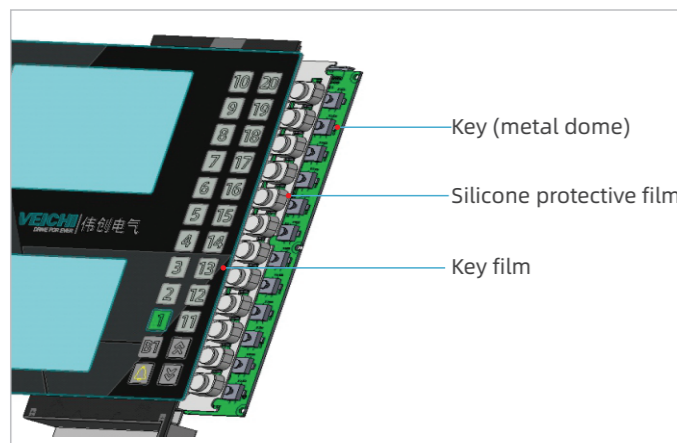

## Key Press Caller

The left and right cages operate independently.



## Portable Operation Box



Compact, portable, and installation-free



Comprehensive functions (identical to the bottom cage operation box), and easy to use

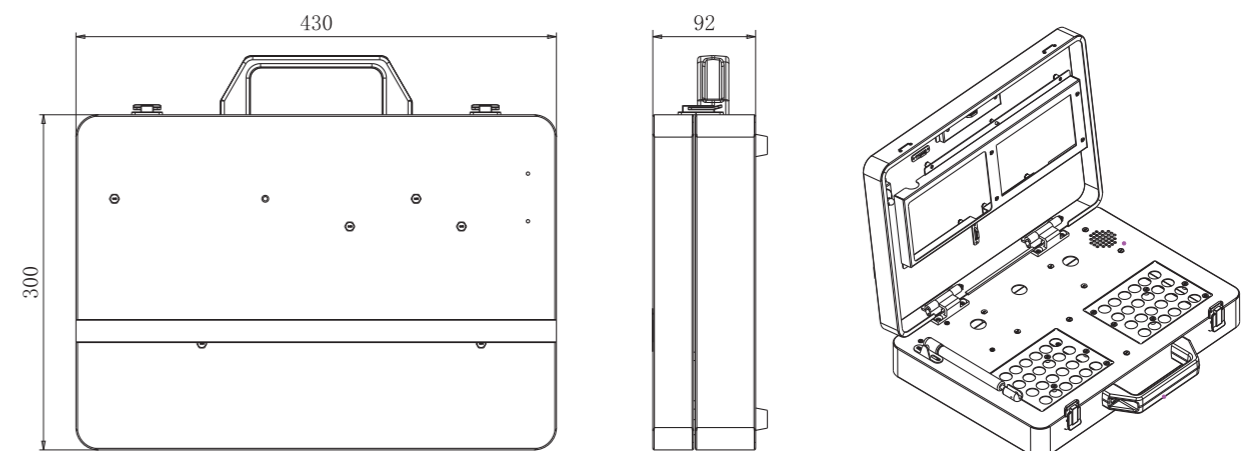

\*Customers can choose between a built-in or a portable box.