



# Safety

---

IP55 Protection class

# Efficiency

---

High efficiency level

# Quiet

---

Low noise and vibration

# Reliability

---

High quality assurance



Honeywell EM series low voltage aluminium motors are widely used for food and beverage, textile, water treatment, HVAC, power, gear boxes, fans, pumps and other industries and applications, which meet the requirements of lightweight, energy saving, environmental friendly trends. The motors can fulfill IE4 Super Premium efficiency motor standard, and meet the requirements of high efficiency motors by various types of machineries.

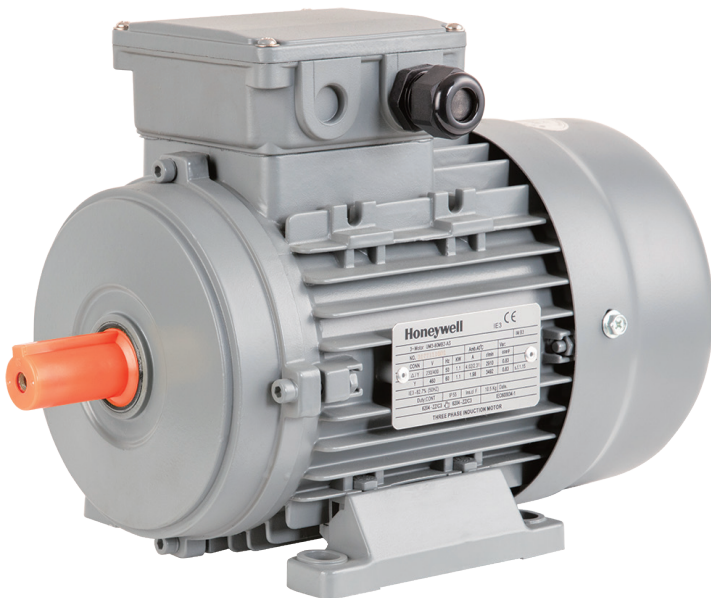

04		Overall Introduction
05		Reference Standards
06		Application
07		Energy Efficiency map
08		Rating Plate
08		Ordering Information
09		Mechanical Features
12		Electrical Features
15		VSD Application
16		VSD Motors
18		Technical Data
24		Variant Code
28		Dimension
32		Mounting Arrangement

# Honeywell EM Series Low Voltage Aluminium Motors Overall Introduction

Honeywell EM series low voltage aluminium motors are widely used for food and beverage, textile, water treatment, HVAC, power, gear boxes, fans, pumps and other industries and applications, which meet the requirements of lightweight, energy saving, environmental friendly trends. The motors can fulfill IE4 Super Premium efficiency motor standard, and meet the requirements of high efficiency motors by various types of machineries. We can also provide customized solutions according to your special requirements.

## Honeywell EM series low voltage aluminium motors outstanding features

- High efficiency and energy saving. (IE4 Super premium efficiency and IE3 premium efficiency, and also comply with GB18613-2020 (Minimum allowable values of energy efficiency grades for motors> Grade 2 and Grade 3)
- High reliability (using highest Honeywell quality level to increase lifetime of the motors)
- Light and flexible (30% lighter than cast iron motors of same output)
- Low vibration and noise (creating comfortable and friendly work environment)
- Environmental friendly (Less energy consumption, carbon dioxide emissions and pollution during manufacturing than cast iron motors of same output)

## Honeywell EM series low voltage aluminium motors technical feature

- Standard voltage and frequency: 380V/50Hz
- Power range: 0.12-15kW (2P, 4P, 6P, 8P), other poles can also be customized
- Elaborate industrial design
- Protection class: IP55 as standard
- Insulation class F with temperature rise class B as standard.
- International brand bearings as standard
- VSD motors as option
- Modular design, less spare parts. Detachable feet, changeable terminal box position and cable outlet direction.

## Honeywell EM series low voltage aluminium motors operation Environment

- Ambient temperature: -20~+40°C
- Altitude: 1000 m
- Relative humidity: 95%
- A suitable canopy cover is required if the motors are installed outdoors with exposure to direct sunlight, rain, snow and ice

IE3  
IE4

2 efficiency level  
Meet a variety  
of application  
requirements



## Reference Standard

**Honeywell EM series low voltage aluminium motors comply with the Following Standards**

Standard Name	IEC Standard	GB Standard
Rotating electrical machines Rating and performance	IEC60034-1	GB/T755
Dimensions and output series for rotating electrical machines	IEC60072-1	GB/T4772.1
Test procedures for three - Phase induction motors	IEC60034-2-1	GB/T1032
Rotating electrical machines Efficiency classes of single-speed, three-phase, cage-induction motors	IEC60034-30	GB18613
Standard voltages	IEC60038	GB/T156
Rotating electrical machines Terminal markings and direction of rotation	IEC60034-8	GB/T1971
General requirements for safety of small and medium size rotating electrical machines	/	GB/T14711
Environmental testing	IEC60068	GB/T2423
Rotating electrical machines Degrees of protection provided by the integral design of rotating electrical machines (IP) Classification	IEC60034-5	GB/T4942.1
Rotating electrical machines Noise limits	IEC60034-9	GB/T10069.3
Rotating electrical machines - Methods of cooling	IEC60034-6	GB/T1993
Rotating electrical machines - Classification of types of constructions and mounting arrangements	IEC60034-7	GB/T997
Rotating electrical machines Mechanical vibration of certain machines with shaft heights 56 mm and higher measurement, evaluation and limits of the vibration severity	IEC60034-14	GB/T10068

# Higher Efficiency and Energy Saving Application

According to incomplete statistics, 75% of the energy consumption generated from motors in industrial production. From the design and manufacture to the type selection, operation, adjustment, maintenance and scrapping of the motor, Honeywell EM4 Series IE4 Super Premium efficiency motors can save the energy consumption, reduce the life cycle operating cost and improve the production efficiency which will provide a huge impetus for the long-term development of the factory. It can reduce environmental pollution and carbon dioxide emissions. Benefiting the social sustainable development. It is remarkable in the energy-saving side, suitable for textile, food and beverage, power, HVAC and other industries and applications.

Textile machinery



Food and beverage



Photovoltaic power generation



HVAC



# Energy Efficiency Map

IEC 60034-30-1: 2014 The minimum efficiency value (50 Hz) (based on the test method specified in IEC 60034-2-1, 2014-06 2nd edition)

Output kw	IE2 High Efficiency				IE3 Premium efficiency				IE4 Super premium efficiency			
	2P	4P	6P	8P	2P	4P	6P	8P	2P	4P	6P	8P
0.75	77.4	79.6	75.9	66.2	80.7	82.5	78.9	75.0	83.5	85.7	82.7	78.4
1.1	79.6	81.4	78.1	70.8	82.7	84.1	81.0	77.7	85.2	87.2	84.5	80.8
1.5	81.3	82.8	79.8	74.1	84.2	85.3	82.5	79.7	86.5	88.2	85.9	82.6
2.2	83.2	84.3	81.8	77.6	85.9	86.7	84.3	81.9	88.0	89.5	87.4	84.5
3	84.6	85.5	83.3	80.0	87.1	87.7	85.6	83.5	89.1	90.4	88.6	85.9
4	85.8	86.6	84.6	81.9	88.1	88.6	86.8	84.8	90.0	91.1	89.5	87.1
5.5	87.0	87.7	86.0	83.8	89.2	89.6	88.0	86.2	90.9	91.9	90.5	88.3
7.5	88.1	88.7	87.2	85.3	90.1	90.4	89.1	87.3	91.7	92.6	91.3	89.3
11	89.4	89.8	88.7	86.9	91.2	91.4	90.3	88.6	92.6	93.3	92.3	90.4
15	90.3	90.6	89.7	88.0	91.9	92.1	91.2	89.6	93.3	93.9	92.9	91.2
18.5	90.9	91.2	90.4	88.6	92.4	92.6	91.7	90.1	93.7	94.2	93.4	91.7
22	91.3	91.6	90.9	89.1	92.7	93.0	92.2	90.6	94.0	94.5	93.7	92.1
30	92.0	92.3	91.7	89.8	93.3	93.6	92.9	91.3	94.5	94.9	94.2	92.7
37	92.5	92.7	92.2	90.3	93.7	93.9	93.3	91.8	94.8	95.2	94.5	93.1
45	92.9	93.1	92.7	90.7	94.0	94.2	93.7	92.2	95.0	95.4	94.8	93.4
55	93.2	93.5	93.1	91.0	94.3	94.6	94.1	92.5	95.3	95.7	95.1	93.7
75	93.8	94.0	93.7	91.6	94.7	95.0	94.6	93.1	95.6	96.0	95.4	94.2
90	94.1	94.2	94.0	91.9	95.0	95.2	94.9	93.4	95.8	96.1	95.6	94.4
110	94.3	94.5	94.3	92.3	95.2	95.4	95.1	93.7	96.0	96.3	95.8	94.7
132	94.6	94.7	94.6	92.6	95.4	95.6	95.4	94.0	96.2	96.4	96.0	94.9
160	94.8	94.9	94.8	93.0	95.6	95.8	95.6	94.3	96.3	96.6	96.2	95.1
200	95.0	95.1	95.0	93.5	95.8	96.0	95.8	94.6	96.5	96.7	96.3	95.4
250	95.0	95.1	95.0	93.5	95.8	96.0	95.8	94.6	96.5	96.7	96.5	95.4
315~1000	95.0	95.1	95.0	93.5	95.8	96.0	95.8	94.6	96.5	96.7	96.6	95.4

## Significant life cycle cost advantage

In the trend of energy saving in China, the concept of end-users and system integrators has been changed from saving the cost of procurement to save operating costs. The benefits in the process of using motors are much more than the cost of procurement. It is estimated that the motor procurement costs account for only about 2% of the total cost of its life cycle, which has a significant cost advantage.

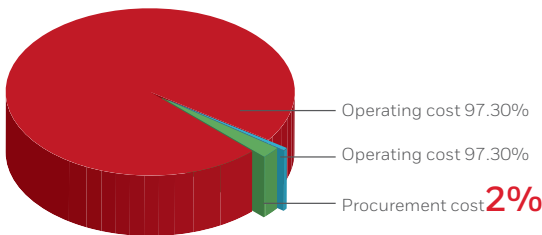

## Saving operating costs

Using Honeywell EM4 series IE4 Super premium efficiency low voltage motor, which can effectively save the electricity consumed during operation. Selecting ultra high efficiency motor, which can take the cost of procurement back by energy-saving in 1 to 2 years.

As an example for 7.5kW EM high performance motor :

### EM4:

Efficiency  $\eta = 92.6\%$

Input power:  $P_1 = P_2 / \eta = 7.5\text{kW} / 92.6\% = 8.10\text{kW}$

### Ordinary efficiency motor:

Efficiency  $\eta = 90.4\%$

Input power:  $P_1 = P_2 / \eta = 7.5\text{kW} / 90.4\% = 8.30\text{kW}$

### Annual operation cost:

Annual operation cost = Input power x Run time x Electric charge

### Annual electric charge saving:

Annual electric charge saving =  $(8.30 - 8.10) \times 8760 \times 1 \approx 1752$  yuan

(Calculated as annual working 8760 hours, electric charge 1 yuan / kWh)

# Rating Plate

## Rated power ≤ 3kW Sample

<b>Honeywell</b>		IEC60034-1		<b>IE3</b>			
3 ~ Motor		EM3-90SA4-GS		IM B3		↔	
No. 317A11180102		Amb. -20~+40°C		Duty: S1			
CONN	V	Hz	kW	A	r/min	cosφ	
Δ/Y	220/380	50	1.5	5.99/3.47	1440	0.77	
Y	440	60	1.73	3.50	1740	0.75	
IE3 - 85.3%(50Hz)							
IP 55	Ins.cl F	6205-ZZ/C3	6205-ZZ/C3	18.5 kg	Date. 202107		
THREE PHASE INDUCTION MOTOR							

## Rated power > 3kW Sample

<b>Honeywell</b>		IEC60034-1		<b>IE3</b>			
3 ~ Motor		EM3-132SA4-GS		IM B3		↔	
No. 317A11180102		Amb. -20~+40°C		Duty: S1			
CONN	V	Hz	kW	A	r/min	cosφ	
Δ/Y	380/660	50	5.5	11.2/6.47	1460	0.83	
Y	440	60	6.33	10.8	1753	0.84	
IE3 - 89.6%(50Hz)							
IP 55	Ins.cl F	6208-ZZ/C3	6208-ZZ/C3	50 kg	Date. 202107		
THREE PHASE INDUCTION MOTOR							

Standard rating plate provides the values of the speed, current and power factor for the four voltages above. Values are for reference only, please seeing the actual rating plate.

# Ordering Information

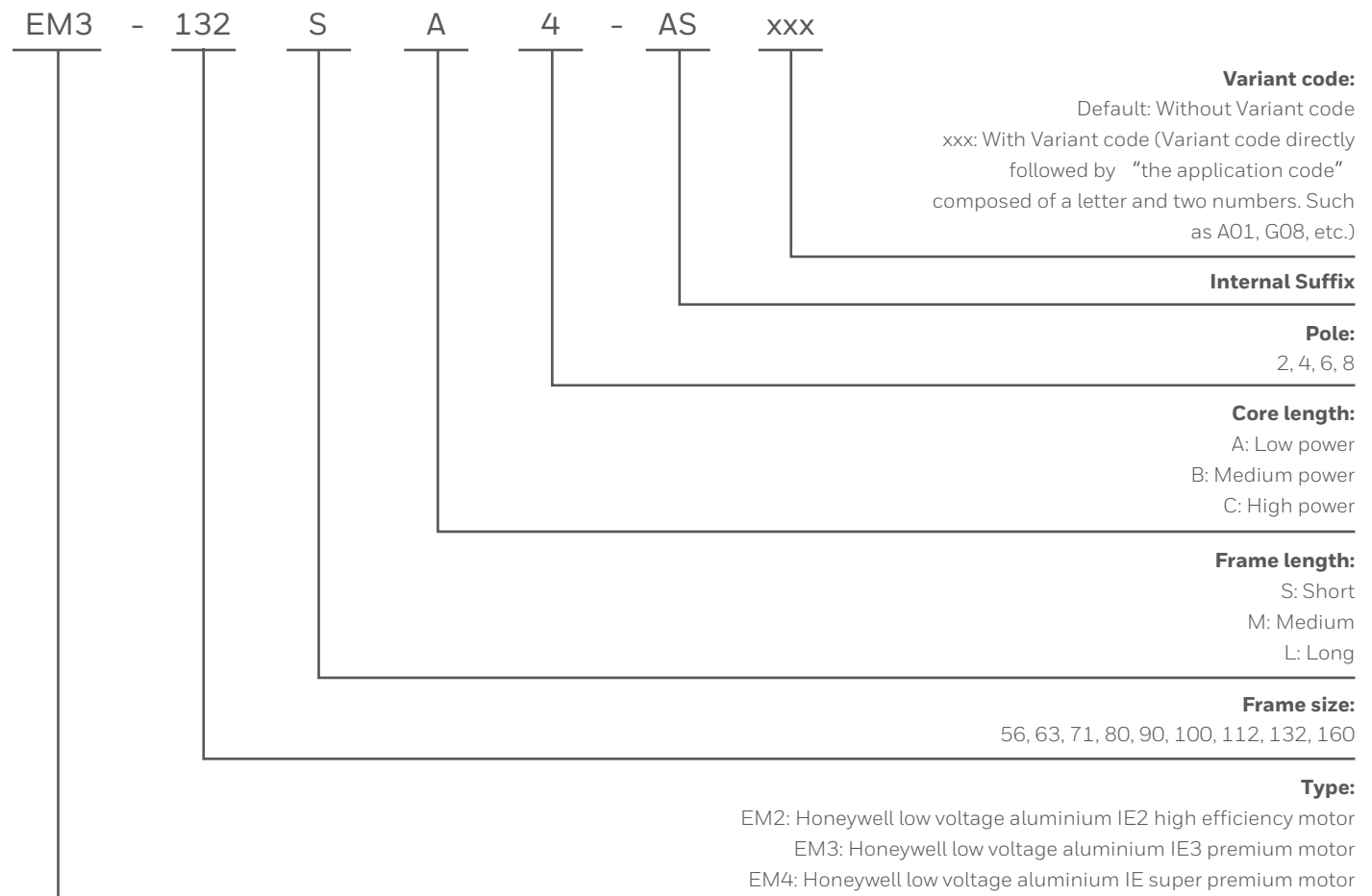

If you need more product information, welcome to the landing website [www.honeywellmotors.com](http://www.honeywellmotors.com) or to inquire the technical hotline 4008766608.

# Mechanical Features

## Terminal Box

The terminal box of Honeywell EM series low voltage aluminium motors locates on the top of the motor as standard. All terminal boxes are fitted with one or two cable glands. Internal earthing is installed inside terminal box.

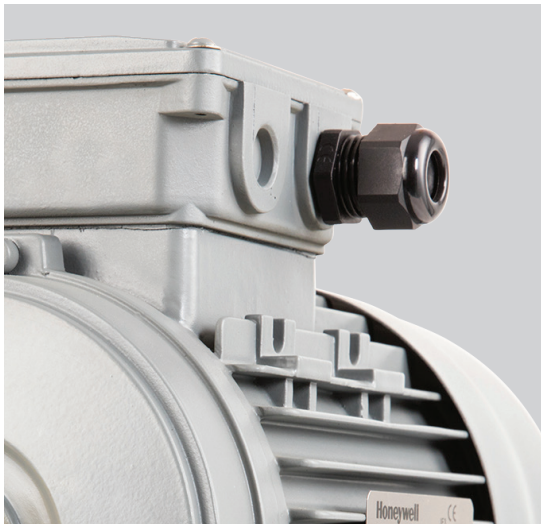

## Terminal Box's Position

Besides the standard position, terminal box can be mounted on right side or left side of the motor. The position of terminal box can be ordered as variant code, using character and numbers.

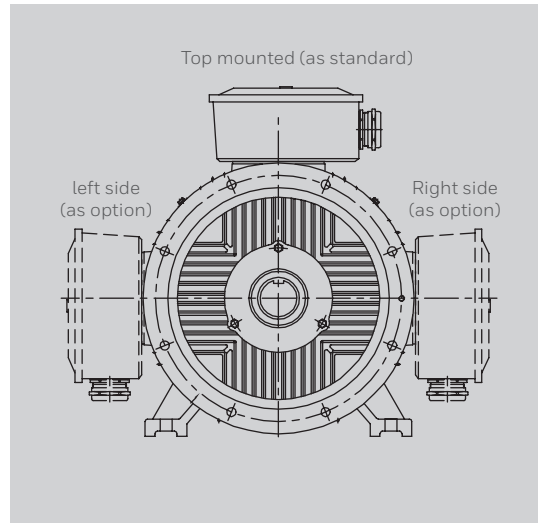

## Plastic Cable Gland

Honeywell EM series low voltage aluminium motors is fitted with 1 to 2 plastic cable glands as standard. One plastic cable gland and one plastic lug for frame size 63 to 132 motor, two plastic cable glands for frame size 160 as standard. Plastic cable gland size is shown in the right table:



## Terminal Box Parameter

Frame size	Cable gland size for main power supply	Suitable for cable outer diameter (mm)
63-71	1-M16x1.5	4-8
80-100	1-M20x1.5	6-12
112-132	2-M25x1.5	13-18
160	2-M32x1.5	22-32

# Mechanical Features

## Cooling

Honeywell EM series low voltage aluminium motor's cooling method is IC411 self-ventilation according to IEC60034-6 standard. Centrifugal cooling fan is mounted on the shaft as standard, and the cooling effect is irrelevant with rotation direction. A separate cooling fan is usually needed when motor is running at very low speed in VSD application, please refer to variable speed drive page.



## Detachable feet and terminal box

With modular design, Honeywell EM series low voltage aluminium motors' feet can be detached, and terminal box position and cable outlet direction can be freely rotated. The modular design can significantly increase flexibility and reduce spare parts.

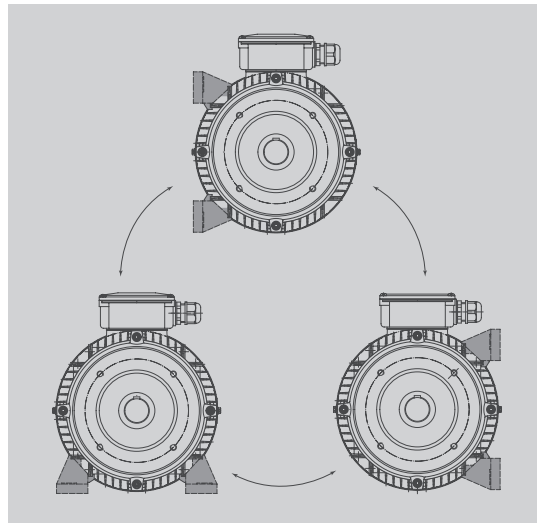

## Corrosion resistant electrostatic powder coating process(As Option)

Honeywell EM series low voltage aluminium motor can use corrosion resistant electrostatic powder coating as option. Compared with traditional painting, powder coating doesn't need any solvent, which eliminates the volatile organic compounds' (VOC) damage to the environment and people. The coating effect of powder coating is superior to the painting process in terms of mechanical strength, adhesion, corrosion resistance and aging resistance.



## Structural Strength

The stator frame of Honeywell EM series low voltage aluminium motor is using high grade aluminium alloy material and high pressure casting process. The cast aluminium frame is with high strength and good surface finish, which is suitable for most industrial and commercial application. Motors from 63 to 90 frame size use cast aluminium end shields as standard. The bearing house of cast aluminium end shields use enhanced wear-resistant structure, which can significantly increase bearing life.

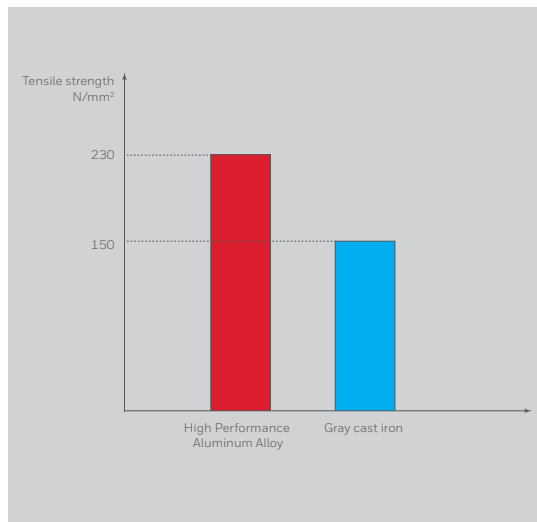

# Mechanical Features

## Bearing System

All types of motor are normally fitted with international brand bearings, and SKF bearings can also be ordered as option. Motors from frame size 63 to 160 are equipped with deep groove ball bearings greased for life. The bearing configuration is shown in the right table, and the lubrication and maintenance of bearings is available in the operation and maintenance manual.

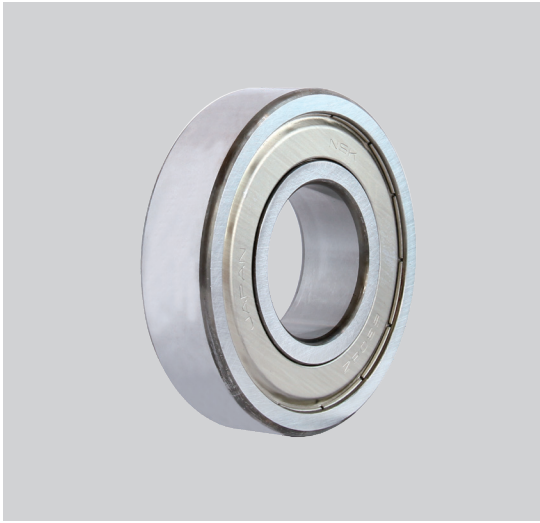

Table of Bearing's Standard Designs

Frame size	Number of poles	Bearings	
		Drive end and mounting	Horizontal Non-drive end
63	2,4,6P	6201-2Z/C3	6201-2Z/C3
71	2,4,6P	6202-2Z/C3	6202-2Z/C3
80	2,4,6P	6204-2Z/C3	6204-2Z/C3
90	2,4,6P	6205-2Z/C3	6205-2Z/C3
100	2,4,6P	6206-2Z/C3	6206-2Z/C3
112	2,4,6P	6306-2Z/C3	6306-2Z/C3
132	2,4,6P	6308-2Z/C3	6308-2Z/C3
160	2,4,6P	6309-2Z/C3	6309-2Z/C3

1. If bearings for special purpose are required, please provide axial force and it's direction.

## Vibration

The motor is well designed, high-precision manufactured and using strict assembly process in order to decrease vibration magnitude. Thus, the lifetime and mechanical performance of the motor has been increased.



Measured Vibration magnitude (r.m.s) at no-load should not exceed the value in the table.

Vibration level	Installation method	56mm≤H≤132		H > 132	
		Displacement/ (um)	Speed/ (mm/s)	Displacement/ (um)	Speed/ (mm/s)
A	Free suspension	45	2.8	45	2.8
	Rigid mounting	-	-	37	2.3(2.8*)
B	Free suspension	18	1.1	29	1.8
	Rigid mounting	-	-	24	1.5(1.8*)

Grade A applies to machines with no special vibration requirements.

Grade B applies to machines with special vibration requirements.

\* This level is the limit when the twice line frequency vibration level is dominant as defined in 8.2 and explained in Figure 7 in IEC60034-14.

# Electrical Features

## Environmental

In accordance with IEC 60034-1, tolerance is the maximum allowed deviation between the test result and the declared value on the rating plate (or in the catalog). Test results are based on test procedures in accordance with IEC 60034-2-1, IEC 60034-9 and IEC 60034-12.

According to IEC 60034, motors are designed to withstand overload capacity of 1.5 times rated current for 2 minutes at rated voltage and frequency.

## Connection

Rated Output Power	Connection (Pre-connected)
≤3kW	Y - connection
> 3kW	Δ - connection

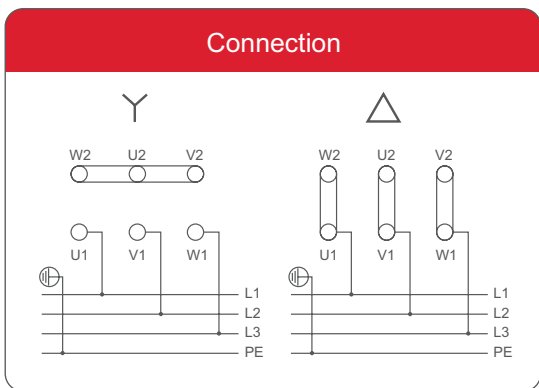

## Rated output

Honeywell EM series low voltage general purpose motor is totally enclosed, fan cooling (IC411), general high efficiency three phase squirrel cage motor, its rated power is output in the case of continuous long period (S1), Ambient temperature: -20°C~+40°C, Altitude 1000 meters above sea level.

## Voltage and Frequency

Rated voltage and frequency are 380V / 50Hz. Motors can also be designed according to customer requirements for other special voltage. For specific details, please see the Variant codes. The impact on temperature rise caused by voltage and frequency fluctuation is defined in IEC 60034-1.

The standard divides the combinations into two zones, zone A and B. Zone A is the combination of voltage deviation ±5% and frequency deviation ±2%. Zone B is the combination of voltage deviation ±10% and frequency deviation +3%/5%.

The motors can supply the rated torque in both zone A and B, but the temperature rise will be higher than at rated voltage and frequency. The motors are to be in operation only for a short period in zone B. The performance data on the rating plate is based on the parameter of rated point.

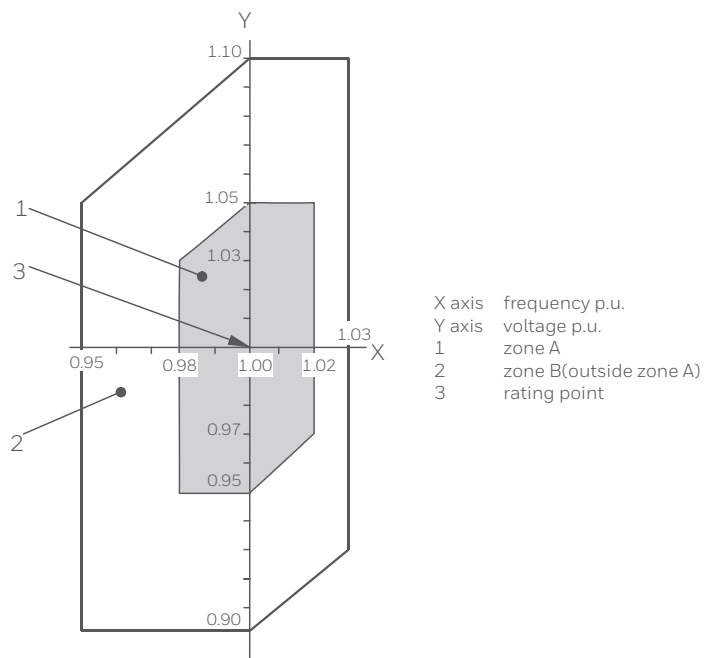

## Electrical data tolerance

	Efficiency	Power factor *	Starting current	Locked torque
			$I_s / I_N$	$T_l / T_N$
$P_N$ (kW) ≤ 150	-15 % (1-η)	-1/6 (1-cosφ)	+20 %	[-15 % + 25 %]
$P_N$ (kW) > 150	-10 % (1-η)		Current	Torque
	Maximum torque	Rotational inertia	Noise grade	
	$T_b / T_N$			
$P_N$ (kW) ≤ 150	-10 %	± 10 %	+3 dB(A)	
$P_N$ (kW) > 150	Torque	Moment of inertia		
	Slip ratio			
$P_N$ (kW) ≤ 1	± 30 %			
$P_N$ (kW) > 1	± 20 %			

\* Tolerance of Power Factor Minimum Absolute Value: 0.02, Maximum Absolute Value: 0.07.

# Electrical Features

## Ambient temperature and Altitude

Normal motors are designed for operation at a maximum ambient temperature of 40°C and at a maximum altitude of 1000 meters above sea level. If a motor is operated at higher ambient temperatures or altitude, it should be derated. Detailed information, please contact Honeywell Motor and Drive.

## The power conversion factor kHT for different heights and / or different ambient temperatures

Altitude	Corresponding to the altitude of the ambient temperature					
	< 30°C	30 ~ 40°C	45°C	50°C	55°C	60°C
1000 m	1.07	1.00	0.96	0.92	0.87	0.82
1500 m	1.04	0.97	0.93	0.89	0.84	0.79
2000 m	1.00	0.94	0.90	0.86	0.82	0.77
2500 m	0.96	0.90	0.86	0.83	0.78	0.74
3000 m	0.92	0.86	0.82	0.79	0.75	0.70
3500 m	0.88	0.82	0.79	0.75	0.71	0.67
4000 m	0.82	0.77	0.74	0.71	0.67	0.63

## Insulation System

Honeywell EM series low voltage general purpose motors use class F insulation with temperature rise class B. The safety margin of the temperature rise is up to 25K, it largely extends the lifetime of the motor, and enables the motor operate reliably under harsh environment.

	B/130°C	F/155°C	H/180°C
Max. ambient temperature	40	40	40
Max. permissible temperature rise	80	105	125
Max. safety margin at max. temperature	10	10	15

Insulation Class and Temperature Rise Class

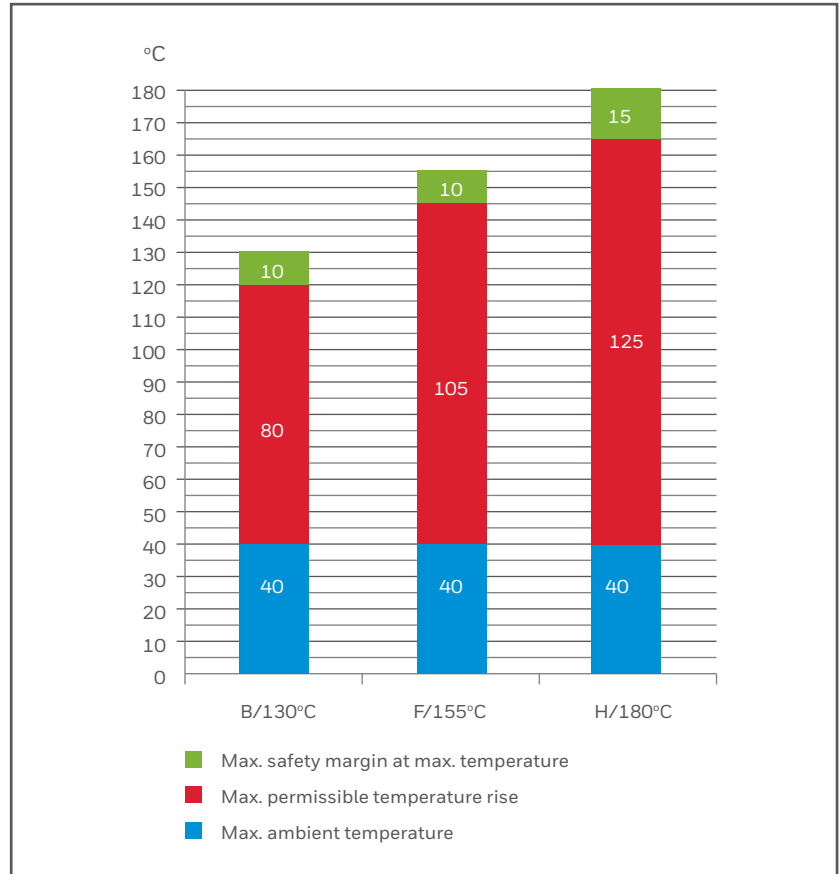

# Electrical Features

## Motor thermal protection (optional, refer to variable code)

- The most common thermal protection of the motor is provided by PTC thermistor motor protection. PTC thermistor is installed in the motor winding. When a limit temperature is reached, the resistance of PTC thermistors will have a step change. The signal will be sent to PTC temperature control module, and the motor's power supply will be cut off.
- Thermal protection switch embedded in winding.
- Platinum Resistance thermometer embedded in winding. Platinum resistance is a high precision and highly sensitive sensor which can cooperate with temperature controller, and show the winding temperature directly. Accordingly, the temperature of warning and tripping could be set.
- Bearing protection In general, maximum allowed operation temperature for bearing is 95°C. For normal workplace, protection is not necessary. For some harsh application and workplace, platinum resistance thermometer for bearing is recommended. It direct touches outer ring of bearing, and direct reflects bearing working temperature. It could detect bearing's operation condition effectively, thus, protect the motor.

## Motor Moisture-proof Protection (optional, refer to variable code)

Honeywell EM series low voltage general purpose motors can select anti-condensation heater and drain holes as optional. Under humid environment, a condensation problem could be generated from inside of the motor after motor stops and cools down. This leads to the decrease of the motor's winding insulation resistance. Thus, the motor insulation is at risk of being burnt. In contrast, if anti-condensation heater is used after motor stops, it makes the temperature of winding always remain higher than ambient temperature 5°C. Therefore, the condensation on insulation after motor cooling down is avoided. There is an additional advantage for anti-condensation heater is to prevent motor starting from extreme cold environment. (aim to low temperature environment).

Note: anti-condensation heater must start working after motor shuts down, shall not work while motor is operating. The detail data of the anti-condensation heater is shown as following table.

Data of the Anti-condensation Heater

Frame Size	Power (W)	Voltage (V)
63~90	20	220~240
100~112	30	220~240
132~160	40	220~240

If other power or voltage's moisture-proof heater is required, please refer to variable code.

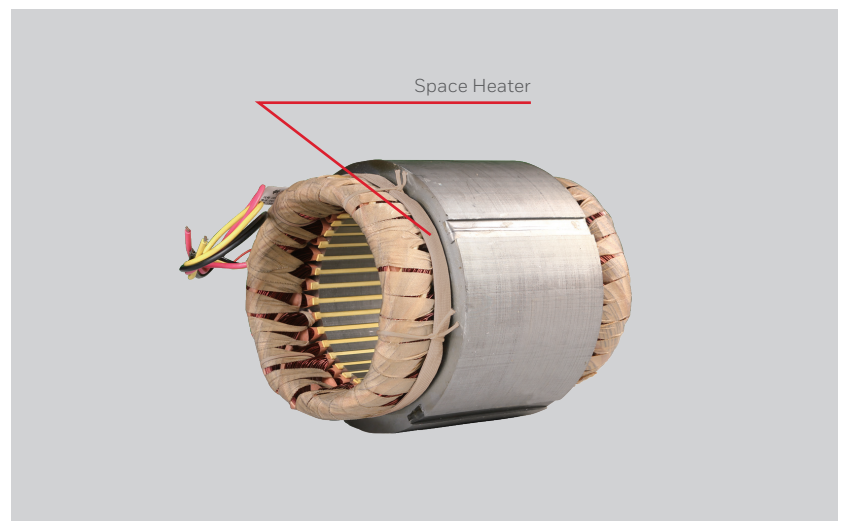

Drain holes allow to drain the condensed water out from the motor. Suitable in humid environment. Especially suitable for the motors which operating under intermittent loads.

# VSD Application

## Technical features

Driven by frequency converter, Honeywell EM series 80-280 low voltage general purpose motors is directly suitable for the Square torque load VSD application such as fans, pumps, compressors and so on.

The voltage that frequency converter produced is not completely sinusoidal voltage which has high harmonic, and it could have relatively high impact on motor's temperature rise, noise and vibration.

Honeywell EM series low voltage general performance motors can operate properly under frequency converter supply voltage up to 500V. But the insulation life will be significantly reduced compared with EM (V) VSD series. At this time the winding temperature rise may reach class F.

Admissible load ability curve by Self-ventilation when driven by frequency converter.

Admissible load ability curve when driven by frequency converter:

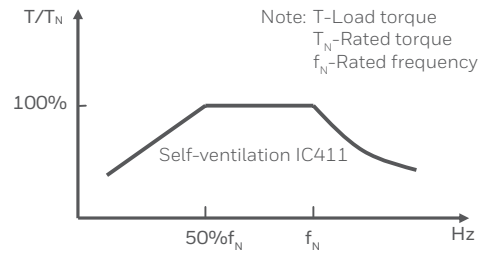

Honeywell EM series low voltage general performance motors can operate above rated speed under inverter control but ensure that the shaft power and load current of the motor do not exceed the rated value at rated speed when the rated speed is exceeded. If the rating plate does not specifically indicate the allowable speed range, the maximum allowable speed must not exceed the following table.

### Maximum allowed speed

Frame Size	2P		4P		6P	
	Max.rpm	fmax	Max.rpm	fmax	Max.rpm	fmax
63~112	5200	87	3600	120	2400	120
132~160	4500	75	2700	90	2400	120

### When motor is driven by frequency converter, the following issues should be taken into account:

- Whether the maximum torque of the motor fulfills the requirement of the machinery need.
- When the motor is driven by the inverter, the electromagnetic noise of the motor will increase.
- When the motor operates above the rated speed, the noise and vibration will increase, and the lifetime of the bearing will decrease.
- As speed increasing, periodical inspection and maintenance of shaft seal's wear condition is needed.

# Motors Specifically Designed for VSD Supply (V Series Motors)

## Technical features

Honeywell EM (V) series frequency converter motors are specialized products which are based on the EM for variable frequency drive. Features:

- Special design for the frequency converter operating conditions, in the wide range of 3-100Hz continuously variable speed
- Using high-level insulation system, extending the life of windings
- Reliable cooling method. The motor can be effectively cooled at any speed. Extending motors' life
- Effectively preventing the generation of shaft currents
- Encoders and overspeed switches can be added as needed
- Flexible type selection and design according to customer requirements

## Honeywell EM(V) VSD motors Type Selection Notices

In order to meet the requirements of the equipment and system, the following information should be provided for type selection:

- Power or torque requirements at different speeds, including rated and maximum torque requirements
- Expected speed range
- Starting requirements, including the number of start times, the load converted to inertia of motor shaft and starting load torque
- Continuous or periodic duty cycle, including overload multiples and duration
- Operating environment, application type
- Frequency converter type, switching frequency, output filter and so on

## Honeywell EM(V) VSD motors application Cautions

### 1) Temperature rise

The voltage of frequency converters is not completely sinusoidal with high harmonic, which will increase the loss and great impact the motor temperature rise.

It is estimated that under the same voltage and frequency the temperature rise under the power supply of the frequency converter will be 8% ~ 12% higher than the direct power supply of the grid. At the same time, with decreasing of the motor speed, the cooling capacity of fan is also rapidly reduced. Different working duties and load changes will also affect the temperature rise of the motor. Different frequency converters control modes, the carrier frequency and the harmonic wave component will affect temperature rise differently.

Temperature not only affect the life of winding insulation, but also affect the bearing lubrication, therefore affecting the bearing life.

Aluminium variable frequency motor using separate cooling and special winding insulation design to enhance heat capacity in combination. It can guarantee the motor life under the variable frequency conditions.

At the same time, choosing larger capacity motors and optimizing the converter output waveform can also reducing the motor temperature rise and extending motor life.

### 2) Torque and load capacity

In the case of good cooling conditions, the output torque is proportional to the ratio between input voltage and frequency. Compared with the rated torque, the output torque of the motor can be kept constant, If the voltage output from the frequency converter drops proportionally to the frequency, when the motor operating at the rated frequency. At this time, the motor is in the constant torque interval. Above the rated frequency, because of the frequency converter output voltage cannot be simultaneously increased, the motor output torque decreases with frequency increasing. At this time, continuous output torque can be proportional to speed. The motor is in the constant power interval.

On type selection, in addition to judging the rated output torque, considering whether the maximum torque of motors suit the equipment is needed. When using a long cable, it is also necessary to consider the torque capacity reducing due to the voltage drop of this cable.

The control algorithms and harmonic components of the different drives are different, so the combination of each motor and drive will have some different load capacities.

The following curve shows the load capacity of VO1 and VO2 in the general case when the motor reaches the temperature rise Class B. The motor can be overloaded a little and operated at the temperature rise Class F. For different temperature rise margins of motors, please contact the technician. In general, the VO3 series motors can be guaranteed the temperature rise class F according to the constant torque load curve of VO1 and VO2 in the range of 25-50Hz (or 30-60Hz). If it is used for the square torque load of fan and pump, with the reducing of speed, the torque of load will square down. It can be guaranteed the temperature rise class B.

Maximum continuous load torque/speed curve as below.

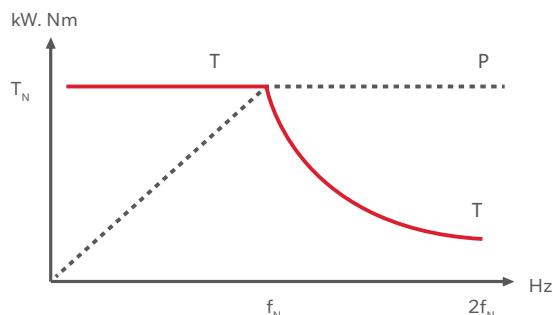

# Motors Specifically Designed for VSD Supply (V Series Motors)

## Honeywell EM(V) VSD motors application Cautions

### 3) Rotate speed range

With the reducing of motor speed, the cooling capability will reduce rapidly. With the raising of motor speed, the noise and vibration will raise significantly. By using the separate cooling fan, the motors can operate in a wide speed range without low-speed crawling phenomenon.

Operation over nominal speed may influence on the noise level and vibration level increasing rapidly, and also reducing the bearing life time. Pay attention on bearing lubrication intervals. Check the condition of shaft seal regularly and replace it if necessary. And metal fan could be considered instead of plastic fan at high speed. The motor should be started at a from low frequency due to the resonance of motor and other parts of system at certain speed as the motor speed range is wide. The resonant frequency could be skipped by setting appropriate parameters on converter. The maximum allowed speed is impacted by mechanical strength, bearing system, rotor stability and other mechanical parameters simultaneously. For detail information, please contact Honeywell Motor and Drive.

### 4) Bearing

In variable speed applications, bearing temperature varies as a function of speed and motor load. The most accurate relubrication intervals can be obtained by measuring the bearing temperature. If the measured temperature is higher than +95°C, the relubrication intervals specified on the lubrication plate or in the maintenance manual must be shortened, or lubricants suitable for high operating temperatures must be used. In case of continuous operation at very low speeds and at very low temperatures (below 20°C), the special greased with additives are needed.

Overmuch bearing currents may damage bearings rapidly. For motor sizes 315 and above, precautionary measures to avoid bearing currents are as standard. There are a variety of measures to prevent shaft currents in system and frequency converter sides, such as using common mode filters,  $d_U/d_T$  filters and non-conductive couplings etc. Also can be used in combination.

### 5) Winding insulation

Under the impact of high-voltage spikes by frequency converter output, insulation is easy to premature failure. Using special treatment can ensure the reliability and longevity of the insulation.

Dielectric stresses on the winding insulation depend on the peak voltage, pulse rise time, frequency, characteristics and length of the cable between drive and motor, winding configuration, and other system parameters.

There are various ways to reduce voltage stress and extend motor life, such as using  $d_U/d_T$  filter, sinusoidal filter, shortening cables between frequency converter and cable. It is recommended to use in combination. It is needed to use  $d_U/d_T$  filter or sinusoidal filter to reduce the voltage stress in the case of frequency converter output voltage 500V.

### 6) Mounting (Cabling, EMC and grounding)

In order to reduce the damage of common mode voltage for motor bearing and meet to ensure compliance with any applicable EMC requirements, motor should be cabled by shield symmetrical cables and EMC glands. For motor above 100kW, a copper plate or strip or at least two separated cables connected between the motor frame and driven equipment for grounding, is required to achieve potential equalization between the motor frame and the driven equipment.

### 7) Rating plates data

As the parameters (such as efficiency) of the frequency converter motor related to the design and performance of frequency converters, so the data of rating plates is based on the power grid.

Honeywell							IEC60034-1		IE3	
3 ~ Motor EM3-90SA4-GS V01					IM B3		↔			
No. 317A11190102			Amb. -20~+40°C		Duty: S1					
CONN	V	Hz	kW	A	r/min	Cosφ				
Y	380	50	1.5	3.47	1440	0.77				
3-50Hz C.T. 7.27Nm 90-1440r/min 50-100Hz C.P. 1.5kW 1440-2880r/min										
IE3 - 85.3%(50Hz)										
IP 55	Ins.cl F	6205-ZZ/C3 $\frac{F_2}{D}$		6205-ZZ/C3		18.5 kg	Date. 202107			
THREE PHASE INDUCTION MOTOR										

# Selection Technical Data

IP55-IC411-Insulation class F, temperature rise class B

IE2 efficiency class according to IEC 60034-30

**EM2**

**2 poles**

**380V/50Hz data**



**IE2**

Motor type	Rated output kW	Rated current A	Efficiency (100%)	Efficiency (75%)	Power factor Cosφ	Rated speed r/min	Starting current times Is/In	Rated torque N.m	Starting torque times Ts/Tn	Max. torque times Tm/Tn	Weight Kg
EM2-63MA2-AS	0.18	0.58	60.4	60.9	0.78	2830	7.0	0.6	2.5	2.8	4.5
EM2-63MB2-AS	0.25	0.75	64.8	65.3	0.78	2830	7.0	0.8	2.5	2.8	5
EM2-71MA2-AS	0.37	1.00	69.5	69.9	0.81	2800	7.0	1.3	3.0	3.0	6.5
EM2-71MB2-AS	0.55	1.38	74.1	74.5	0.82	2820	7.0	1.9	3.0	3.0	7
EM2-80MA2-AS	0.75	1.77	77.4	77.2	0.83	2875	5.3	2.5	2.5	3.0	8.2
EM2-80MB2-AS	1.1	2.53	79.6	79.7	0.83	2875	7.0	3.7	3.2	3.8	9.2
EM2-90SA2-AS	1.5	3.34	81.3	81.4	0.84	2890	7.1	5.0	2.7	3.5	13.1
EM2-90LA2-AS	2.2	4.73	83.2	82.9	0.85	2890	6.9	7.3	2.4	3.0	16
EM2-100LA2-AS	3	6.19	84.6	84.5	0.87	2891	8.0	9.9	3.2	4.0	22.3
EM2-112MA2-AS	4	8.05	85.8	86.1	0.88	2914	7.5	13.1	2.5	3.0	30.4
EM2-132SA2-AS	5.5	10.9	87.0	86.7	0.88	2937	7.5	17.9	2.7	3.5	46
EM2-132SB2-AS	7.5	14.5	88.1	88.4	0.89	2940	7.5	24.4	2.4	3.3	51.2
EM2-160MA2-AS	11	21.0	89.4	89.1	0.89	2930	7.6	35.9	2.2	2.9	90
EM2-160MB2-AS	15	28.4	90.3	90.5	0.89	2930	7.6	48.9	2.3	3.0	100
EM2-160LA2-AS	18.5	34.7	90.9	91.0	0.89	2937	7.4	60.2	2.3	3.1	111

IP55-IC411-Insulation class F, temperature rise class B

IE2 efficiency class according to IEC 60034-30

**EM2**

**4 poles**

**380V/50Hz data**

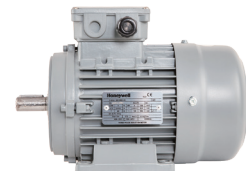

**IE2**

Motor type	Rated output kW	Rated current A	Efficiency (100%)	Efficiency (75%)	Power factor Cosφ	Rated speed r/min	Starting current times Is/In	Rated torque N.m	Starting torque times Ts/Tn	Max. torque times Tm/Tn	Weight Kg
EM2-63MA4-AS	0.12	0.44	59.1	60.2	0.70	1360	5.2	0.8	2.2	2.4	4
EM2-63MB4-AS	0.18	0.60	64.7	65.1	0.70	1360	5.2	1.3	2.2	2.4	6
EM2-71MA4-AS	0.25	0.79	68.5	68.9	0.70	1380	5.2	1.7	2.5	2.5	6.5
EM2-71MB4-AS	0.37	1.09	72.7	73.1	0.71	1380	5.2	2.6	2.5	2.5	7
EM2-80MA4-AS	0.55	1.51	77.1	77.9	0.72	1400	6.0	3.8	2.3	2.4	10
EM2-80MB4-AS	0.75	1.91	79.6	79.3	0.75	1400	5.0	5.1	2.4	2.9	11
EM2-90SA4-AS	1.1	2.74	81.4	81.1	0.75	1440	6.0	7.3	3.0	3.5	13.1
EM2-90LA4-AS	1.5	3.67	82.8	82.5	0.75	1440	6.8	9.9	3.2	3.8	16.3
EM2-100LA4-AS	2.2	4.90	84.3	84.4	0.81	1440	7.0	14.6	3.0	3.5	23.5
EM2-100LB4-AS	3	6.50	85.5	85.3	0.82	1440	7.0	19.9	2.6	3.3	26
EM2-112MA4-AS	4	8.56	86.6	86.9	0.82	1445	7.5	26.4	3.5	4.0	33.1
EM2-132SA4-AS	5.5	11.6	87.7	87.4	0.82	1455	6.4	36.1	2.2	2.8	46.1
EM2-132MA4-AS	7.5	15.5	88.7	88.5	0.83	1455	7.0	49.2	2.4	3.0	54.3
EM2-160MA4-AS	11	21.9	89.8	90.1	0.85	1460	6.9	72.0	2.5	2.9	95
EM2-160LA4-AS	15	29.2	90.6	90.8	0.86	1460	7.5	98.1	2.5	3.0	115

# Selection Technical Data

IP55-IC411-Insulation class F, temperature rise class B

IE2 efficiency class according to IEC 60034-30

**EM2**

**6 poles**

**380V/50Hz data**

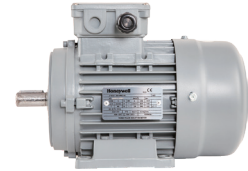

**IE2**

Motor type	Rated output kW	Rated current A	Efficiency (100%)	Efficiency (75%)	Power factor Cosφ	Rated speed r/min	Starting current times Is/In	Rated torque N.m	Starting torque times Ts/Tn	Max. torque times Tm/Tn	Weight Kg
EM2-63MB6-AS	0.12	0.60	50.6	50.1	0.60	880	4.0	1.3	1.9	2.0	6
EM2-71MA6-AS	0.18	0.77	56.6	56.3	0.63	920	4.0	1.9	1.9	2.0	6.5
EM2-71MB6-AS	0.25	0.96	61.6	61.8	0.64	920	4.3	2.6	1.9	2.1	7
EM2-80MA6-AS	0.37	1.34	67.6	67.7	0.62	950	5.0	3.7	1.9	2.0	10.5
EM2-80MB6-AS	0.55	1.79	73.1	73.2	0.64	950	5.0	5.6	1.9	2.0	12
EM2-90SA6-AS	0.75	2.09	75.9	76.1	0.72	934	4.5	7.7	2.2	2.4	13
EM2-90LA6-AS	1.1	2.93	78.1	77.9	0.73	945	4.5	11.1	2.4	2.6	16.5
EM2-100LA6-AS	1.5	3.86	79.8	80.1	0.74	945	4.2	15.2	1.8	2.2	23.2
EM2-112MA6-AS	2.2	5.52	81.8	81.9	0.74	960	4.5	21.9	2.3	2.8	32
EM2-132SA6-AS	3	7.39	83.3	83.6	0.74	964	4.5	29.7	1.8	2.4	42
EM2-132MA6-AS	4	9.71	84.6	84.5	0.74	965	5.0	39.6	2.3	2.7	51
EM2-132MB6-AS	5.5	13.0	86.0	85.9	0.75	965	5.5	54.4	1.9	2.8	61
EM2-160MA6-AS	7.5	16.8	87.2	87.0	0.78	970	6.5	73.8	2.0	3.0	120
EM2-160LA6-AS	11	23.9	88.7	88.4	0.79	970	7.5	108	2.4	3.3	133

IP55-IC411-Insulation class F, temperature rise class B

IE2 efficiency class according to IEC 60034-30

**EM2**

**8 poles**

**380V/50Hz data**

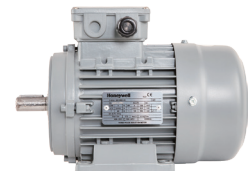

**IE2**

Motor type	Rated output kW	Rated current A	Efficiency (100%)	Efficiency (75%)	Power factor Cosφ	Rated speed r/min	Starting current times Is/In	Rated torque N.m	Starting torque times Ts/Tn	Max. torque times Tm/Tn	Weight Kg
EM2-71MB8-AS	0.12	0.70	48.0	46.0	0.54	690	4.3	1.7	1.9	2.1	7
EM2-80MA8-AS	0.18	1.03	48.5	46.0	0.55	710	4.5	2.4	1.8	2.0	10.5
EM2-80MB8-AS	0.25	1.28	54.0	52.0	0.55	710	4.5	3.4	1.8	2.0	12
EM2-90SA8-AS	0.37	1.67	56.1	54.0	0.60	710	4.5	5.0	1.8	2.0	13
EM2-90LA8-AS	0.55	2.22	61.7	59.0	0.61	710	4.5	7.4	1.8	2.0	16.5
EM2-100LA8-AS	0.75	2.57	66.2	65.0	0.67	710	6.1	10.1	1.8	2.0	20
EM2-100LB8-AS	1.1	3.42	70.8	70.0	0.69	710	6.1	14.8	1.8	2.0	21.5
EM2-112MA8-AS	1.5	4.39	74.1	74.6	0.70	710	6.4	20.2	1.8	2.0	31
EM2-132SA8-AS	2.2	6.07	77.6	77.9	0.71	710	6.4	29.6	1.8	2.0	40
EM2-132MA8-AS	3	7.80	80.0	80.5	0.73	710	6.8	40.4	1.8	2.0	48

# Selection Technical Data

IP55-IC411-Insulation class F, temperature rise class B

IE3 efficiency class according to IEC 60034-30

**EM3**

**2 poles**

**380V/50Hz data**

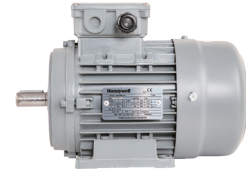

**IE3**

Motor type	Rated output kW	Rated current A	Efficiency (100%)	Efficiency (75%)	Power factor Cosφ	Rated speed r/min	Starting current times Is/In	Rated torque N.m	Starting torque times Ts/Tn	Max. torque times Tm/Tn	Weight Kg
EM3-63MA2-AS	0.18	0.55	65.9	66.3	0.75	2780	4.9	0.6	2.7	2.8	5
EM3-63MB2-AS	0.25	0.71	69.7	70.4	0.77	2780	5.6	0.9	3.3	3.4	6
EM3-71MA2-AS	0.37	0.98	73.8	74.1	0.78	2780	4.9	1.3	2.8	2.8	7
EM3-71MB2-AS	0.55	1.36	77.8	78.3	0.79	2850	6.2	1.8	3.4	3.2	7.5
EM3-80MA2-AS	0.75	1.72	80.7	80.6	0.82	2900	7.3	2.5	2.5	3.0	9.5
EM3-80MB2-AS	1.1	2.43	82.7	83.0	0.83	2910	8.7	3.6	2.8	3.5	10.5
EM3-90SA2-AS	1.5	3.22	84.2	84.8	0.84	2900	8.5	4.9	2.4	3.2	15
EM3-90LA2-AS	2.2	4.58	85.9	86.2	0.85	2915	8.5	7.2	2.6	3.5	19
EM3-100LA2-AS	3	6.02	87.1	87.9	0.87	2910	8.5	9.8	3.2	3.5	25
EM3-112MA2-AS	4	7.84	88.1	88.5	0.88	2920	8.6	13.1	2.6	3.0	34
EM3-132SA2-AS	5.5	10.6	89.2	89.5	0.88	2920	8.6	18.0	2.5	2.8	49.5
EM3-132SB2-AS	7.5	14.4	90.1	90.7	0.88	2925	8.5	24.5	2.5	3.0	55
EM3-160MA2-AS	11	20.6	91.2	91.6	0.89	2945	8.8	35.7	2.7	3.6	99
EM3-160MB2-AS	15	27.9	91.9	92.0	0.89	2945	9.0	48.6	2.6	3.6	108
EM3-160LA2-AS	18.5	34.2	92.4	92.5	0.89	2940	9.0	60.1	2.7	3.6	118

IP55-IC411-Insulation class F, temperature rise class B

IE3 efficiency class according to IEC 60034-30

**EM3**

**4 poles**

**380V/50Hz data**

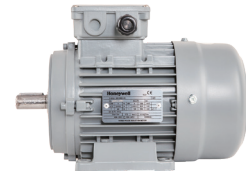

**IE3**

Motor type	Rated output kW	Rated current A	Efficiency (100%)	Efficiency (75%)	Power factor Cosφ	Rated speed r/min	Starting current times Is/In	Rated torque N.m	Starting torque times Ts/Tn	Max. torque times Tm/Tn	Weight Kg
EM3-63MA4-AS	0.12	0.43	64.8	63.2	0.66	1330	3.5	0.9	2.5	2.7	5
EM3-63MB4-AS	0.18	0.59	69.9	68.6	0.66	1360	3.6	1.3	2.5	2.7	6
EM3-71MA4-AS	0.25	0.75	73.5	73.7	0.69	1380	4.6	1.7	2.3	2.6	7
EM3-71MB4-AS	0.37	1.04	77.3	77.5	0.70	1400	5.1	2.5	2.6	2.8	9
EM3-80MA4-AS	0.55	1.44	80.8	80.9	0.72	1430	6.2	3.7	2.6	3.0	11
EM3-80MB4-AS	0.75	1.84	82.5	82.6	0.75	1445	7.2	5.0	3.0	3.6	12
EM3-90SA4-AS	1.1	2.61	84.1	84.0	0.76	1445	8.0	7.3	2.5	3.0	17
EM3-90LA4-AS	1.5	3.47	85.3	84.8	0.77	1445	8.1	9.9	2.9	3.2	22
EM3-100LA4-AS	2.2	4.76	86.7	86.6	0.81	1455	8.1	14.4	3.1	3.7	27
EM3-100LB4-AS	3	6.34	87.7	87.7	0.82	1450	8.6	19.8	3.2	3.7	33
EM3-112MA4-AS	4	8.37	88.6	88.5	0.82	1455	8.8	26.3	3.0	3.7	41
EM3-132SA4-AS	5.5	11.2	89.6	89.5	0.83	1460	8.6	36.0	2.8	3.6	53
EM3-132MA4-AS	7.5	15.0	90.4	90.2	0.84	1460	8.6	49.1	3.2	3.6	63
EM3-160MA4-AS	11	21.5	91.4	91.2	0.85	1465	8.8	71.7	3.5	3.8	111
EM3-160LA4-AS	15	28.8	92.1	92.0	0.86	1465	8.8	97.8	3.5	3.8	117

# Selection Technical Data

IP55-IC411-Insulation class F, temperature rise class B

IE3 efficiency class according to IEC 60034-30

**EM3**

**6 poles**

**380V/50Hz data**

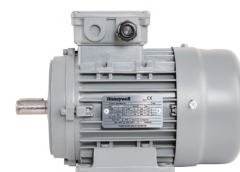

**IE3**

Motor type	Rated output kW	Rated current A	Efficiency (100%)	Efficiency (75%)	Power factor Cosφ	Rated speed r/min	Starting current times Is/In	Rated torque N.m	Starting torque times Ts/Tn	Max. torque times Tm/Tn	Weight Kg
EM3-63MB6-AS	0.12	0.54	57.7	56.1	0.58	860	3.0	1.3	1.9	2.2	6.5
EM3-71MA6-AS	0.18	0.73	63.9	62.3	0.59	920	3.2	1.9	2.4	2.3	7
EM3-71MB6-AS	0.25	0.94	68.6	67.3	0.59	920	3.2	2.6	2.1	2.3	8
EM3-80MA6-AS	0.37	1.25	73.5	72.1	0.61	950	5.7	3.7	1.9	2.3	11.5
EM3-80MB6-AS	0.55	1.75	77.2	76.2	0.62	950	5.5	5.5	2.0	2.3	12.5
EM3-90SA6-AS	0.75	2.03	78.9	78.0	0.71	955	6.0	7.5	1.9	2.3	15
EM3-90LA6-AS	1.1	2.83	81.0	81.2	0.73	955	6.0	11.0	2.6	3.0	20
EM3-100LA6-AS	1.5	3.78	82.5	82.7	0.73	960	6.5	14.9	2.6	3.1	24
EM3-112MA6-AS	2.2	5.36	84.3	84.5	0.74	965	6.6	21.8	2.2	3.0	34
EM3-132SA6-AS	3	7.20	85.6	85.7	0.74	968	7.8	29.6	2.7	3.8	45
EM3-132MA6-AS	4	9.46	86.8	86.9	0.74	968	7.8	39.5	2.3	2.7	52
EM3-132MB6-AS	5.5	12.7	88.0	88.5	0.75	968	8.1	54.3	2.3	2.7	62
EM3-160MA6-AS	7.5	16.2	89.1	89.2	0.79	970	7.8	73.8	2.4	3.1	123
EM3-160LA6-AS	11	23.1	90.3	90.2	0.80	970	7.8	108	1.9	2.4	138

IP55-IC411-Insulation class F, temperature rise class B

IE3 efficiency class according to IEC 60034-30

**EM3**

**8 poles**

**380V/50Hz data**

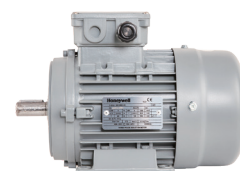

**IE3**

Motor type	Rated output kW	Rated current A	Efficiency (100%)	Efficiency (75%)	Power factor Cosφ	Rated speed r/min	Starting current times Is/In	Rated torque N.m	Starting torque times Ts/Tn	Max. torque times Tm/Tn	Weight Kg
EM3-71MB8-AS	0.12	0.69	50.7	48.7	0.52	690	2.6	1.7	1.9	2.3	7
EM3-80MA8-AS	0.18	0.88	58.7	56.8	0.53	710	3.0	2.4	1.8	2.2	11.5
EM3-80MB8-AS	0.25	1.12	64.1	62.3	0.53	710	3.2	3.4	2.0	2.4	12.5
EM3-90SA8-AS	0.37	1.40	69.3	67.4	0.58	710	4.0	5.0	1.9	2.5	15.5
EM3-90LA8-AS	0.55	1.94	73.0	71.2	0.59	710	4.0	7.4	1.8	2.5	18.5
EM3-100LA8-AS	0.75	2.34	75.0	72.1	0.65	700	6.2	10.2	1.8	2.0	22
EM3-100LB8-AS	1.1	3.12	77.7	75.2	0.69	710	6.2	14.8	1.8	2.0	27.5
EM3-112MA8-AS	1.5	4.08	79.7	77.8	0.70	705	6.7	20.3	1.8	2.0	34
EM3-132SA8-AS	2.2	5.75	81.9	80.4	0.71	705	6.7	29.8	1.8	2.0	44
EM3-132MA8-AS	3	7.58	83.5	82.6	0.72	705	6.9	40.6	1.8	2.0	52.5

# Selection Technical Data

IP55-IC411-Insulation class F, temperature rise class B

IE4 efficiency class according to IEC 60034-30

**EM4**

**2 poles**

**50Hz 380V**

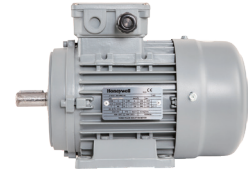

**IE4**

Motor type	Rated output kW	Rated current A	Efficiency (100%)	Power factor Cosφ	Rated speed r/min	Starting current times Is/In	Rated torque N.m	Starting torque times Ts/Tn	Max. torque times Tm/Tn	Weight Kg
EM4-80MA2-AS	0.75	1.64	83.5	0.83	2900	8.5	2.5	2.6	3.0	10.6
EM4-80MB2-AS	1.1	2.36	85.2	0.83	2910	8.5	3.6	2.6	3.2	12
EM4-90SA2-AS	1.5	3.10	86.5	0.85	2910	9.5	4.9	2.6	3.2	17
EM4-90LA2-AS	2.2	4.42	88.0	0.86	2910	9.5	7.2	2.6	3.2	21
EM4-100LA2-AS	3	5.88	89.1	0.87	2910	9.5	9.8	2.7	3.3	28
EM4-112MA2-AS	4	7.67	90.0	0.88	2920	9.5	13.1	2.6	3.3	40
EM4-132SA2-AS	5.5	10.4	90.9	0.88	2920	9.5	18.0	2.5	3.3	52
EM4-132SB2-AS	7.5	14.0	91.7	0.89	2925	9.5	24.5	2.5	3.3	64
EM4-160MA2-AS	11	20.3	92.6	0.89	2950	9.5	35.6	2.7	3.3	109
EM4-160MB2-AS	15	27.4	93.3	0.89	2950	9.5	48.6	2.6	3.3	119
EM4-160LA2-AS	18.5	33.7	93.7	0.89	2950	9.5	59.9	2.7	3.3	130

IP55-IC411-Insulation class F, temperature rise class B

IE4 efficiency class according to IEC 60034-30

**EM4**

**4 poles**

**50Hz 380V**

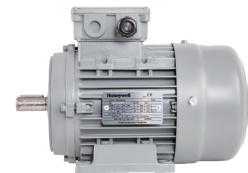

**IE4**

Motor type	Rated output kW	Rated current A	Efficiency (100%)	Power factor Cosφ	Rated speed r/min	Starting current times Is/In	Rated torque N.m	Starting torque times Ts/Tn	Max. torque times Tm/Tn	Weight Kg
EM4-80MB4-AS	0.75	1.80	85.7	0.74	1445	8.0	5.0	2.8	3.2	15
EM4-90SA4-AS	1.1	2.56	87.2	0.75	1445	8.5	7.3	2.6	3.2	17
EM4-90LA4-AS	1.5	3.40	88.2	0.76	1450	9.0	9.9	2.6	3.2	21
EM4-100LA4-AS	2.2	4.73	89.5	0.79	1455	9.0	14.4	2.7	3.3	31
EM4-100LB4-AS	3	6.30	90.4	0.8	1455	9.0	19.7	2.7	3.3	35
EM4-112MA4-AS	4	8.34	91.1	0.8	1455	9.5	26.3	2.7	3.3	49
EM4-132SA4-AS	5.5	11.4	91.9	0.8	1460	9.5	36.0	2.7	3.6	75
EM4-132MA4-AS	7.5	15.2	92.6	0.81	1460	9.5	49.1	2.8	3.6	85
EM4-160MA4-AS	11	21.6	93.3	0.83	1465	9.5	71.7	2.8	3.3	124
EM4-160LA4-AS	15	28.9	93.9	0.84	1480	9.5	96.8	2.8	3.3	131

# Selection Technical Data

IP55-IC411-Insulation class F, temperature rise class B

IE4 efficiency class according to IEC 60034-30

**EM4**

**6 poles**

**50Hz 380V**

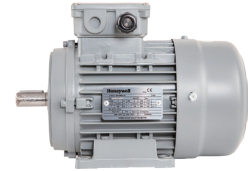

**IE4**

Motor type	Rated output	Rated current	Efficiency (100%)	Power factor	Rated speed	Starting current times	Rated torque	Starting torque times	Max. torque times	Weight
	kW	A		Cosφ	r/min	Is/In	N.m	Ts/Tn	Tm/Tn	Kg
EM4-90SA6-AS	0.75	1.97	82.7	0.7	955	6.0	7.5	2.1	2.4	17
EM4-90LA6-AS	1.1	2.83	84.5	0.7	955	6.5	11.0	2.1	2.4	23
EM4-100LA6-AS	1.5	3.74	85.9	0.71	960	6.5	14.9	2.2	2.6	31
EM4-112MA6-AS	2.2	5.39	87.4	0.71	965	7.5	21.8	2.2	2.6	48
EM4-132SA6-AS	3	7.25	88.6	0.71	968	7.8	29.6	2.5	3.0	62
EM4-132MA6-AS	4	9.43	89.5	0.72	968	8.0	39.5	2.3	2.6	66
EM4-132MB6-AS	5.5	12.8	90.5	0.72	968	9.0	54.3	2.3	2.6	83
EM4-160MA6-AS	7.5	16.4	91.3	0.76	975	8.0	73.5	2.4	3.0	138
EM4-160LA6-AS	11	23.5	92.3	0.77	980	8.5	107	2.2	2.5	155

IP55-IC411-Insulation class F, temperature rise class B

IE4 efficiency class according to IEC 60034-30

**EM4**

**8 poles**

**50Hz 380V**

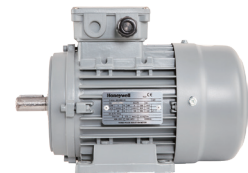

**IE4**

Motor type	Rated output	Rated current	Efficiency (100%)	Power factor	Rated speed	Starting current times	Rated torque	Starting torque times	Max. torque times	Weight
	kW	A		Cosφ	r/min	Is/In	N.m	Ts/Tn	Tm/Tn	Kg
EM4-100LA8-AS	0.75	2.20	78.4	0.66	710	7.0	10.1	2.0	2.0	31
EM4-100LB8-AS	1.1	3.09	80.8	0.67	710	7.0	14.8	2.0	2.0	35
EM4-112MA8-AS	1.5	4.00	82.6	0.69	710	7.0	20.2	2.0	2.0	48
EM4-132SA8-AS	2.2	5.65	84.5	0.70	720	7.5	29.2	1.8	2.0	59
EM4-132MA8-AS	3	7.58	85.9	0.70	720	7.8	39.8	1.8	2.0	65
EM4-160MA8-AS	4	9.83	87.1	0.71	720	7.9	53.1	1.8	2.0	119
EM4-160MB8-AS	5.5	13.1	88.3	0.72	720	8.1	73.0	1.8	2.0	138
EM4-160LA8-AS	7.5	17.2	89.3	0.74	720	7.8	99.5	1.8	2.0	155

# Variant Code

Variant Group	Variant Code	Description	63	71	80	90	100	112	132	160	NOTE
Mounting arrangement A	A01	IMB3	S	S	S	S	S	S	S	S	As standard
	A02	IMB5	P	P	P	P	P	P	P	P	
	A03	IMV1	P	P	P	P	P	P	P	P	with protection roof
	A04	IMB35	P	P	P	P	P	P	P	P	(1)
	A05	IM14	P	P	P	P	P	P	P	P	
	A06	IMB34	P	P	P	P	P	P	P	NA	
	A07	Other moutingng arrangement	R	R	R	R	R	R	R	R	
Insulation C	C01	Insulation class F	S	S	S	S	S	S	S	S	As standard
	C02	Insulation class H	P	P	P	P	P	P	P	P	
Material D	D01	Cast Iron B3 D-endshield	P	P	P	P	S	S	S	S	
	D02	Cast Iron B3 ND-endshield	P	P	P	P	S	S	S	S	
	D03	Cast Iron B5 flange endshield	P	P	P	P	P	P	P	S	
	D04	Cast Iron B14 flange endshield	P	P	P	P	P	P	P	S	
	D05	Aluminium B3 D-endshield	S	S	S	S	NA	NA	NA	P	
	D06	Aluminium B3 ND-endshield	S	S	S	S	NA	NA	NA	P	
	D07	Aluminium B5 flange endshield	S	S	S	S	S	S	S	P	
	D08	Aluminium B14 flange endshield	S	S	S	S	S	S	S	NA	
Shaft E	E01	Two shaft extensions according to catalog drawings	P	P	P	P	P	P	P	P	(2)
	E02	Shaft extension with closed keyway	S	S	S	S	S	S	S	S	As standard
	E03	Shaft extension with threaded holes	S	S	S	S	S	S	S	S	(3)
	E04	Special shaft extension at D-End, standard shaft material	R	R	R	R	R	R	R	R	
	E05	Special shaft extension at N-End, standard shaft material	R	R	R	R	R	R	R	R	
Protection F	F01	Degree of protection IP55	S	S	S	S	S	S	S	S	As standard
	F02	Degree of protection IP56	P	P	P	P	P	P	P	P	
	F03	Degree of protection IP65	P	P	P	P	P	P	P	P	
	F04	Drain hole with plug	P	P	P	P	P	P	P	P	
	F05	External Earthing	P	P	P	P	P	P	P	P	As standard
	F06	Stanless steel bolts(304#)	P	P	P	P	P	P	P	P	
	F08	Radial seal at D-end.	S	S	S	S	S	S	S	P	Oil seal
	F09	TH design	P	P	P	P	P	P	P	P	
	F14	Moisture-proof treatment for stator and rotor core	P	P	P	P	P	P	P	P	

S = Included as standard

R = On request

NA = Not applicable

P = Applicable

(1) Round flange as standard.

(2) Technical confirmation needed.

(3) As standard. Size and depth acc. to dimension drawing

# Variant Code

Variant Group	Variant Code	Description	63	71	80	90	100	112	132	160	NOTE	
Bearing and grease G	G01	Roller bearing at D-end	NA	NA	NA	NA	NA	NA	NA	P	(1)	
	G02	Sealed bearings	S	S	S	S	S	S	S	S	(2)	
	G03	Heat-resistant grease	P	P	P	P	P	P	P	P	(3)	
	G04	Cold-resistant grease	P	P	P	P	P	P	P	P	(4)	
	G05	Transport lock for bearings	NA	NA	NA	NA	NA	NA	NA	R		
	G06	Pt100 3-wire in bearings	NA	NA	NA	NA	NA	NA	NA	P	(5)	
	G07	Pt100 2-wire in bearings	NA	NA	NA	NA	NA	NA	NA	P	(5)	
	G08	SKF bearing	P	P	P	P	P	P	P	P	(6)	
	G11	63-series bearing	NA	NA	NA	NA	NA	S	S	S	(7)	
	G13	Bearings regreasable via grease nipples	NA	NA	NA	NA	NA	NA	NA	P		
Terminal box H	H01	Terminal box at top	S	S	S	S	S	S	S	S	(8)	
	H02	Cable entry from D-end	R	R	R	R	R	R	R	P		
	H03	Cable entry from N-end	P	P	P	P	P	P	P	P	(9)	
	H04	Cable entry LHS (seen from D-end)	P	P	P	P	P	P	P	P		
	H05	Special terminal box	R	R	R	R	R	R	R	R	(10)	
	H06	Terminal box RHS (seen from D-end)	P	P	P	P	P	P	P	P		
	H07	Terminal box LHS (seen from D-end)	P	P	P	P	P	P	P	P		
	H08	Flying leads with standard length, no terminal box	R	R	R	R	R	R	R	R	R	(11)
	H09	Flying leads with special length, no terminal box,	R	R	R	R	R	R	R	R	R	(10)
	H10	Special extended cable, no terminal box	R	R	R	R	R	R	R	R	R	(10)
	H11	Another set of standard terminal box attached	R	R	R	R	R	R	R	R	R	
	H14	Two standard metal cable glands	P	P	P	P	P	P	P	P	P	
	H15	Two standard plastic cable glands	P	P	P	P	P	P	P	P	P	(12)
H17	Terminal box at N-end	R	R	R	R	R	R	R	R	R	(13)	
H19	Reserve non-standard cable entry	R	R	R	R	R	R	R	R	R	(10)	
H20	One standard metal cable glands	P	P	P	P	P	P	P	P	P		
Certificate J	J12	CE mark	R	R	R	R	R	R	R	R		

S = Included as standard

R = On request

NA = Not applicable

P = Applicable

- (1) Recommend to order G05 for at the same time, otherwise, there may be damage during transportation. Note that if the radial load is lower than the minimum load requirement for cylindrical roller bearings, the bearing may make a squeezing sound.
- (2) 63-132 as standard. 2Z sealing as standard. Please note that the grease life in sealed bearings is generally much lower than the bearing life.
- (3) Heat resistant +160°C, otherwise technical confirmation needed.
- (4) Code resistant -40°C, otherwise technical confirmation needed.
- (5) One at D-end and one at N-end, wire leads in the main terminal box.
- (6) Technical confirmation needed if not standard bearing type, sealing and grease.
- (7) 80-132 technical confirmation needed.
- (8) As standard for foot mounted motor.
- (9) Cable entry may interfere with lifting lug. Technical confirmation needed.
- (10) Technical confirmation needed.
- (11) Flying leads length(from the cover): 500mm for 90 and below, 1000mm for 100-160, 1500mm for 180 and above.
- (12) For 63-132, one plastic cable gland and one plastic plug as standard.
- (13) Technical confirmation needed for foot mounted motor.

# Variant Code

Variant Group	Variant Code	Description	63	71	80	90	100	112	132	160	NOTE
Cooling system K	K01	Plastic fan	S	S	S	S	S	S	S	S	As standard
	K02	Aluminum alloy fan	NA	NA	P	P	P	P	P	P	
	K03	Without fan and fan cover	P	P	P	P	P	P	P	P	(1)
	K04	Separate cooling fan	P	P	P	P	P	P	P	P	(2)
Stator winding L	L01	Bimetal detectors, break type (NCC), (3 in series), 150°C, in stator winding	P	P	P	P	P	P	P	P	
	L02	Bimetal detectors, break type (NCC), (3 in series), 170°C, in stator winding	P	P	P	P	P	P	P	P	
	L03	Pt100 2-wire in stator winding, 1 per phase	P	P	P	P	P	P	P	P	(3)
	L04	Pt100 2-wire in stator winding, 2 per phase	P	P	P	P	P	P	P	P	(3)
	L05	Pt100 3-wire in stator winding, 1 per phase	P	P	P	P	P	P	P	P	(3)
	L06	Pt100 3-wire in stator winding, 2 per phase	P	P	P	P	P	P	P	P	(3)
	L07	PTC - thermistors (3 in series), 150°C, in stator winding	P	P	P	P	P	P	P	P	
	L08	PTC - thermistors (3 in series), 170°C, in stator winding	P	P	P	P	P	P	P	P	
	L09	Special winding (standard output, non-standard voltage or frequency)	P	P	P	P	P	P	P	P	(4)
	L10	Special winding (non-standard power, duty, non-standard voltage, service factor, etc.)	R	R	R	R	R	R	R	R	(4)
Rating and identification plate M	M01	Restamping voltage, frequency, output or duty	P	P	P	P	P	P	P	P	(4)
	M02	Mounting of additional identification plate, stainless steel	P	P	P	P	P	P	P	P	(4)
	M03	Additional rating plate delivered loose	P	P	P	P	P	P	P	P	(4)
Test N	N01	Type test report from a catalogue motor, 380V 50Hz	R	R	R	R	R	R	R	R	
	N02	Type test with report for one motor from specific delivery batch	P	P	P	P	P	P	P	P	
	N03	Routine test report	P	P	P	P	P	P	P	P	
	N04	Vibration level test	R	R	R	R	R	R	R	R	(4)
	N05	Noise level test	R	R	R	R	R	R	R	R	(4)
Packing P	P01	Export wooden box packaging	R	R	R	R	R	R	R	R	

S = Included as standard

R = On request

NA = Not applicable

P = Applicable

(1) Cooling method IC418 as standard. The motor is cooled by the customer's equipment. It is customer's responsibility to provide enough ventilation and cooling for motor. Otherwise technical confirmation needed.

(2) 380V 50Hz fan motor as standard. Fan motor voltage and frequency is the same as main motor. If the main motor has multiple voltage and frequency, fan motor voltage and frequency should be provided when ordered.

(3) Wire leads without terminals as standard.

(4) Technical confirmation needed.

# Variant Code

Variant Group	Variant Code	Description	63	71	80	90	100	112	132	160	NOTE
Balancing Q	Q01	Full-key balancing	P	P	P	P	P	P	P	P	
	Q02	Half key balancing	S	S	S	S	S	S	S	S	As standard
	Q03	Balanced without key	P	P	P	P	P	P	P	P	
	Q04	Vibration class B	P	P	P	P	P	P	P	P	
Heating elements R	R01	Heating element, 100-120 V	P	P	P	P	P	P	P	P	
	R02	Heating element, 200 - 240 V	P	P	P	P	P	P	P	P	
Painting T	T01	Primer paint only	P	P	P	P	P	P	P	P	
	T02	Special paint color, standard grade	P	P	P	P	P	P	P	P	(1)
	T03	Paint thickness report	R	R	R	R	R	R	R	R	(1)
Variable speed drives V	V01	Frequency range 3-100Hz(standard output power, not possible for 2 poles, cooling method IC416)	P	P	P	P	P	P	P	P	(2)
	V02	Frequency range 3-60Hz(standard output power, applicable for 2 poles, cooling method IC416)	P	P	P	P	P	P	P	P	
	V03	Frequency range 30-60Hz(or 25-50Hz, standard output power, cooling method IC411)	P	P	P	P	P	P	P	P	(3)
	V04	VSD rating plate data according to request	R	R	R	R	R	R	R	R	(4)
	V05	Dedicated VSD design for centrifugal fan and pump(standard output power, 5-50Hz square torque load,cooling method IC411)	P	P	P	P	P	P	P	P	(5)
Warranty W	W01	Extended warranty	R	R	R	R	R	R	R	R	
Specal industry design X	X06	Low axial displacement (pump application, bearing fixed at D-end)	P	P	P	P	P	P	P	P	
Other U	U00	Other requirements	R	R	R	R	R	R	R	R	(1)

S = Included as standard

R = On request

NA = Not applicable

P = Applicable

(1) Technical confirmation needed.

(2) Only applicable to standard out power, rated point is 380V 50Hz or 440V 60Hz, please provide when ordered. No special temperature rise, altitude requirements, and electrical performance required. Separate fan voltage and frequency is 380V 50Hz or 440V 60Hz as standard (according to order). Below 50Hz (or 60Hz) is constant torque speed regulation range, and above 50Hz (or 60Hz) is constant power speed regulation range. VSD rating plate included. For frame size 315 and above, measures to prevent shaft current is included. Motors cannot be used in industries and applications with frequent starts and frequent overloads, such as port machinery and hoisting, pulp and papermaking, metallurgy and mining, and foundry machinery.

(3) Only applicable to standard out power, rated point is 380V 50Hz or 440V 60Hz, please provide when ordered. No special temperature rise, altitude requirements, and electrical performance required. No separate fan cooling. Below 50Hz (or 60Hz) is constant torque speed regulation range, and above 50Hz (or 60Hz) is constant power speed regulation range. VSD rating plate included. For frame size 315 and above, measures to prevent shaft current is included. Motors cannot be used in industries and applications with frequent starts and frequent overloads, such as port machinery and hoisting, pulp and papermaking, metallurgy and mining, and foundry machinery.

(4) Applicable to non-standard out power, voltage, speed range and so on. Technical confirmation needed. Specific requirements (such as rated power, voltage, frequency, frequency range, torque/power characteristics, cooling method, etc.) is required when ordered. Separate fan voltage and frequency is same as main motor as standard if not provided.

(5) Only applicable to standard out power, rated point is 380V 50Hz. No special temperature rise, altitude requirements, and electrical performance required. No separate fan cooling. Below 50Hz (or 60Hz) is square torque speed regulation range. VSD rating plate included. For frame size 315 and above, measures to prevent shaft current is included.

# Dimension Drawings

## Frame size 80~132

### Foot-mounted motor IMB3

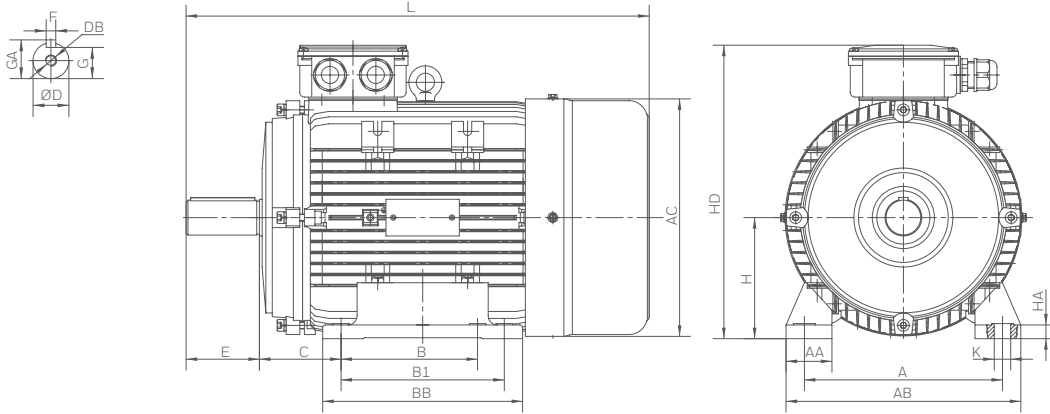

### Large flange mounted motors IMB5

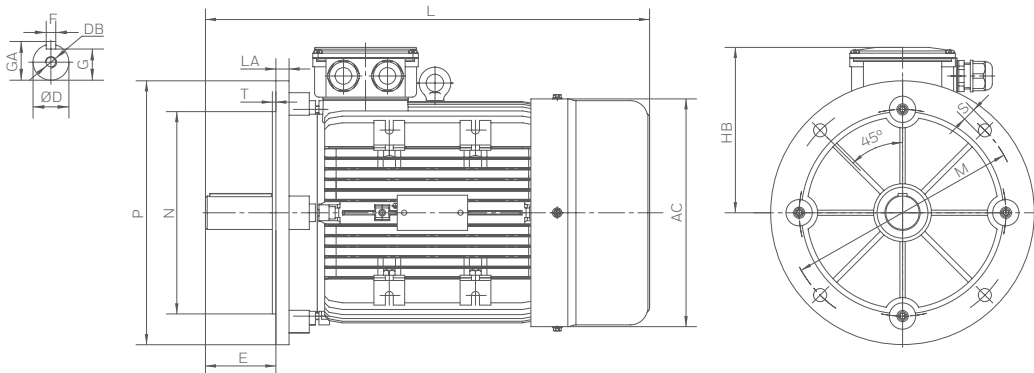

### Foot-and flanged-mounted motor IMB35

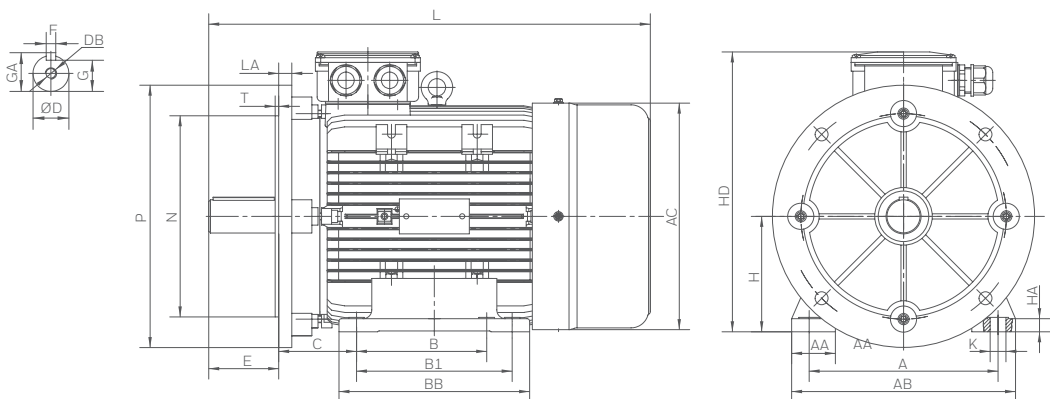

# Dimension Drawings

Small flange mounted motor IMB14

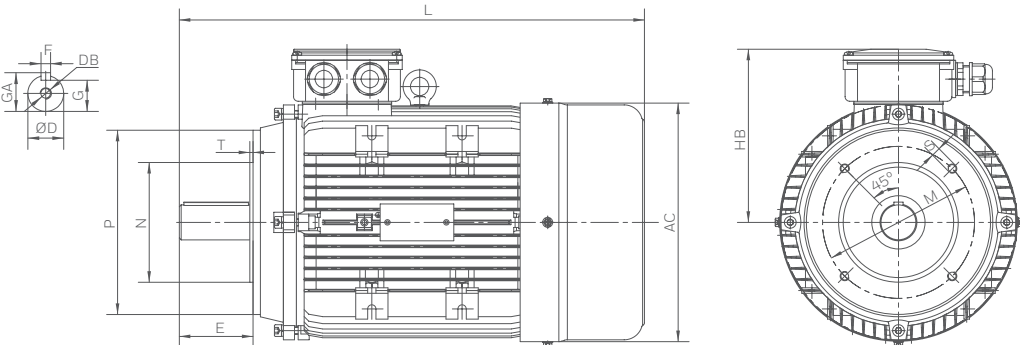

Foot and small flange installation motor IMB34

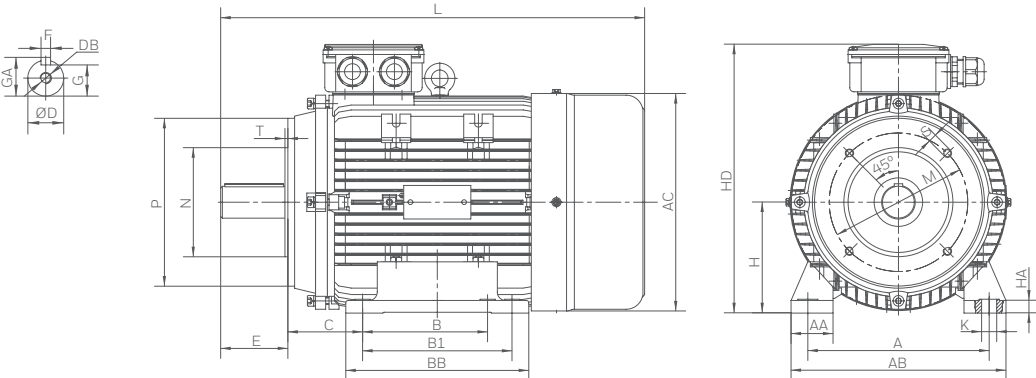

# Dimension Drawings

## Frame size EM2, EM3-80~132

### IIMB3; IMB35; IMB34

Frame	A	AA	AB	AC	B	B1	BB	C	D	DB	E	G	GA	H	K	HA	HD	EM2-L	EM3-L
63	100	22	122	120	80	-	108	40	11	M4	23	8.5	12.5	63	7	9	170	220	220
71	112	24	138	139	90	-	113	45	14	M5	30	11	16	71	7	9	190	260	260
80	125	27	160	158	100	-	122	50	19	M6	40	15.5	21.5	80	10	12	210	290	305
90S	140	35	178	175	100	125	155	56	24	M8	50	20	27	90	10	13	225	310	345
90L	140	35	178	175	125	-	155	56	24	M8	50	20	27	90	10	13	225	335	370
100	160	42	205	198	140	-	176	63	28	M10	60	24	31	100	12	12	250	380	410
112	190	45	222	228	140	-	180	70	28	M10	60	24	31	112	12	13	285	400	410
112 4P	190	45	222	228	140	-	180	70	28	M10	60	24	31	112	12	13	285	400	435
132S	216	50	257	268	140	-	180	89	38	M12	80	33	41	132	12	15	325	470	470
132M	216	50	257	268	178	-	218	89	38	M12	80	33	41	132	12	15	325	510	510

### IMB5; IMV1; IMV3; IMB35

Frame	HB	LA	M	N	P	S	T
63	107	9	115	95	140	10	3
71	119	9	130	110	160	10	3.5
80	130	10	165	130	200	12	3.5
90	135	10	165	130	200	12	3.5
100	150	14	215	180	250	14.5	4
112	173	14	215	180	250	14.5	4
132	193	15	265	230	300	14.5	4

### IMB14; IMB34

Frame	HB	LA	M	N	P	S	T
63	107	75	60	90	M5	2.5	2.5
71	119	85	70	105	M6	2.5	2.5
80	130	100	80	120	M6	3	3
90	135	115	95	136	M8	3	3
100	150	130	110	164	M8	3.5	3.5
112	173	130	110	160	M8	3.5	3.5
132	193	165	130	200	M10	3.5	3.5

# Dimension Drawings

## Frame size EM4-80~132

### IIMB3; IMB35; IMB34

Frame	A	AA	AB	AC	B	B1	BB	C	D	DB	E	G	GA	H	K	HA	HD	L
80	125	27	160	169	100	-	122	50	19	M6	40	15.5	21.5	80	10	12	210	300
80MB4	125	27	160	169	100	-	122	50	19	M6	40	15.5	21.5	80	10	12	210	310
90S	140	35	178	185	100	125	155	56	24	M8	50	20	27	90	10	13	225	340
90L 2P	140	35	178	185	125	-	155	56	24	M8	50	20	27	90	10	13	225	365
90L 4-6P	140	35	178	185	125	-	155	56	24	M8	50	20	27	90	10	13	225	375
100	160	42	205	208	140	-	176	63	28	M10	60	24	31	100	12	12	250	405
100LB4	160	42	205	208	140	-	176	63	28	M10	60	24	31	100	12	12	250	430
112 2P	190	45	222	228	140	-	180	70	28	M10	60	24	31	112	12	13	285	435
112 4-8P	190	45	222	235	140	178	180	70	28	M10	60	24	31	112	12	13	295	460
132S 2P	216	50	257	268	140	-	180	89	38	M12	80	33	41	132	12	15	325	470
132S 4-8P	216	50	270	293	140	-	180	89	38	M12	80	33	41	132	12	15	345	510
132M 2P	216	50	257	268	178	-	218	89	38	M12	80	33	41	132	12	15	325	510
132M 4-8P	216	50	270	293	178	-	218	89	38	M12	80	33	41	132	12	15	345	540

### IMB5; IMV1; IMV3; IMB35

Frame	HB	LA	M	N	P	S	T
80	130	10	165	130	200	12	3.5
90	135	10	165	130	200	12	3.5
100	150	14	215	180	250	14.5	4
112 2P	173	14	215	180	250	14.5	4
112 4-8P	183	14	215	180	250	14.5	4
132 2P	193	15	265	230	300	14.5	4
132 4-8P	213	15	265	230	300	14.5	4

### IMB14; IMB34

Frame	HB	M	N	P	S	T
80	130	100	80	120	M6	3
90	135	115	95	136	M8	3
100	150	130	110	164	M8	3.5
112 2P	173	130	110	160	M8	3.5
112 4-8P	183	130	110	160	M8	3.5
132 2P	193	165	130	200	M10	3.5
132 4-8P	213	165	130	200	M10	3.5

# Dimension Drawings

## Frame size 160

### Foot-mounted motor IMB3

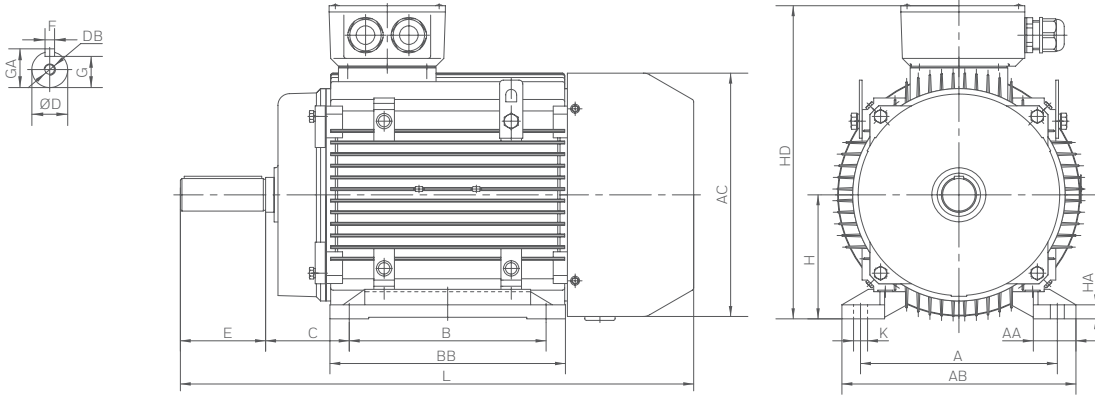

### Flanged-mounted motor IMB5

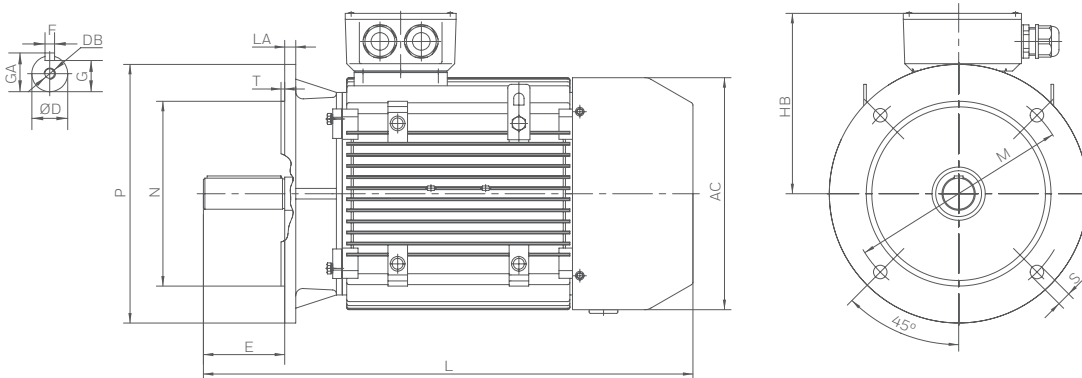

### Footed-and flanged-mounted motor IMB35

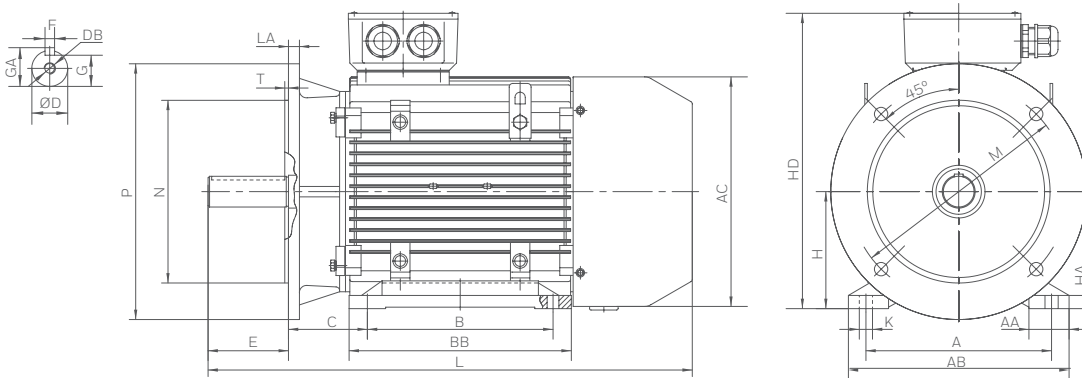

# Dimension Drawings

## Frame size EM2, EM3, EM4-160

### IIMB3; IMB35; IMB34

Frame	A	AA	AB	AC	B	B1	BB	C	D	DB	E	G	GA	H	K	HA	HD	L
160M	254	55	302	314	210	-	260	108	42	M16	110	37	45	160	15	18	410	625
160L	254	55	302	314	254	-	304	108	42	M16	110	37	45	160	15	18	410	670

### IMB5; IMV1; IMV3; IMB35

Frame	HB	LA	M	N	P	S	T
160	250	15	300	250	350	18.5	5

### IMB14; IMB34

Frame	HB	M	N	P	S	T
160	250	215	180	250	M12	4

# Mounting Arrangement

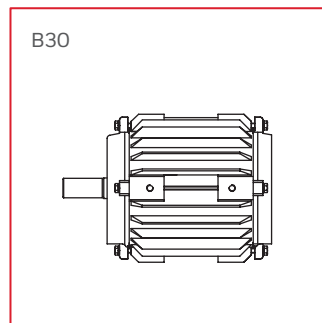
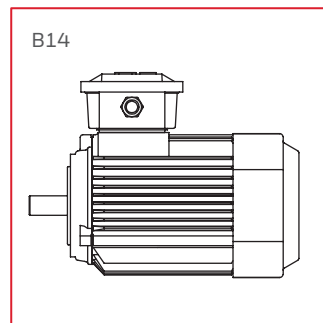
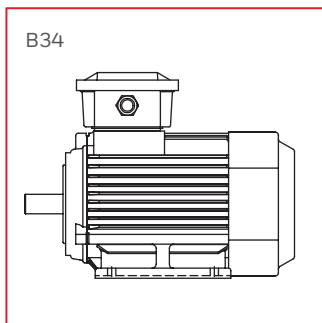
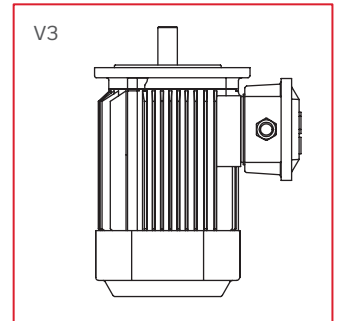
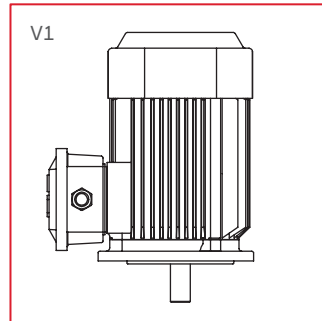
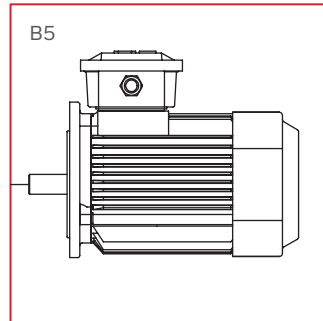
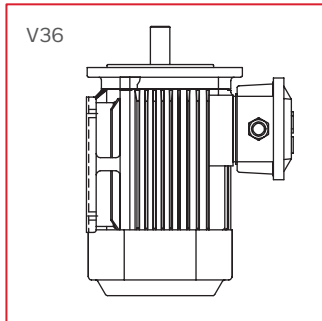
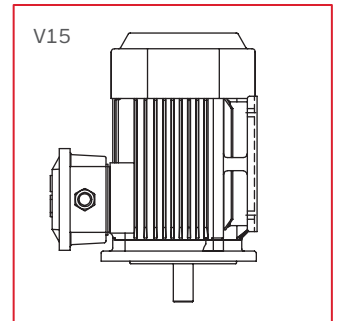
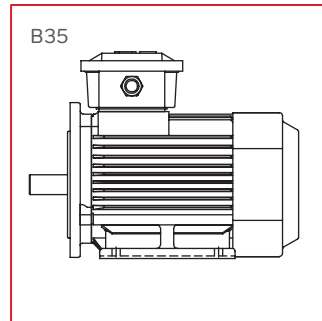
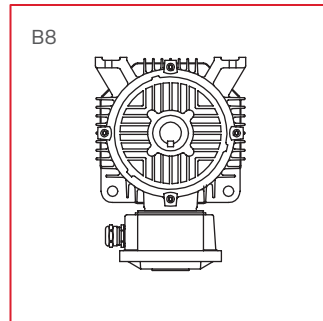
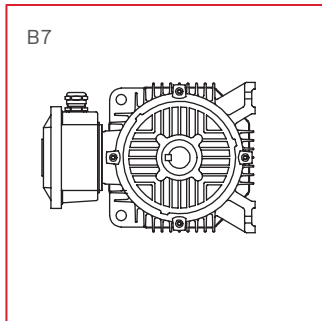
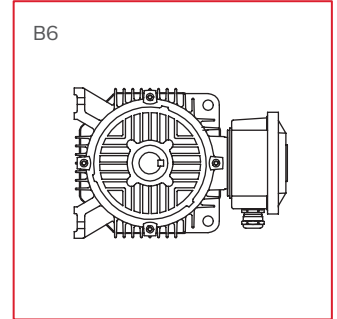
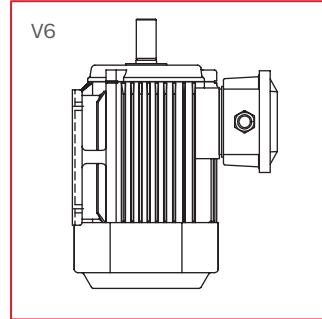
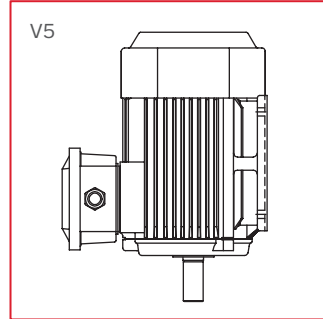
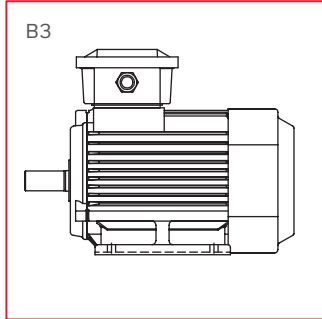



We reserve the right to make technical modifications or change the content of this document without prior notice.  
We reserve the right of final interpretation of the content.

**Customer Hotline: 400 876 6608**

Room F301, Bldg 7, No.1188 Lianhang Rd,  
Shanghai, 201112, P.R.China

[www.honeywellmotors.com](http://www.honeywellmotors.com)

The Honeywell Trademark is used under license from Honeywell International Inc.

Honeywell International Inc. makes no representations or warranties with respect to this product.

This product is distributed by GTS Electric (Shanghai) Co., Ltd.

GTS\_CA\_EM | V02 | Aug/2024  
©2024 GTS Electric (Shanghai) Co., Ltd.

**Honeywell**