

VEICHI

FT1 Series Frameless Motor

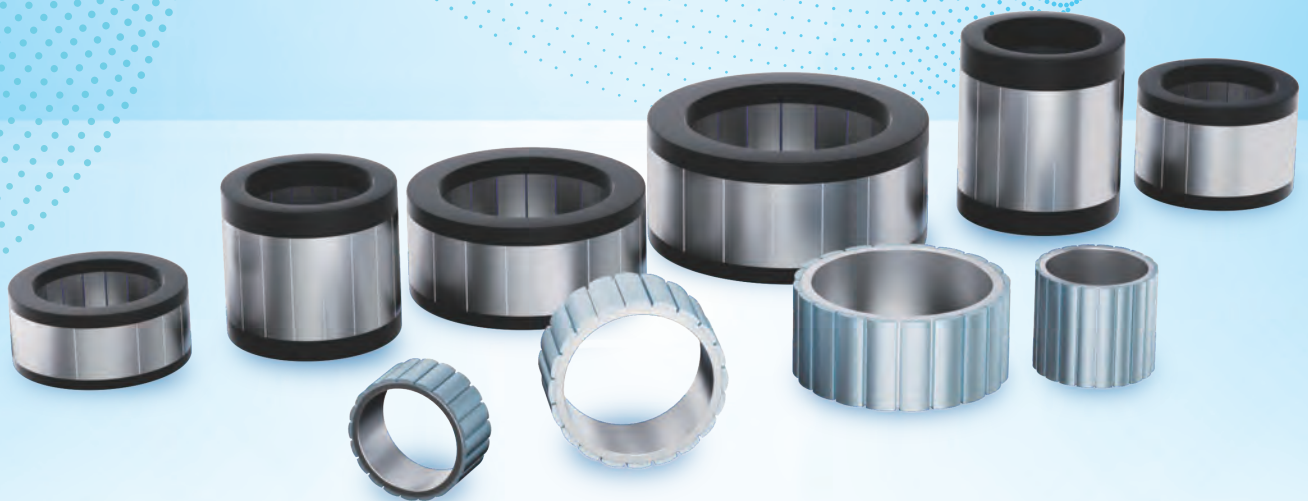

Stock Code: 688698

About Us



VEICHI Electric (stock code: 688698) has always been dedicated to the field of electrical drive and industrial control since its establishment, and now it is a high-tech enterprise engaged in R&D, production, and sales of industrial automation products in one. With R&D and production bases in Suzhou, Shenzhen and Xi'an, and a wholly-owned subsidiary in India, VEICHI now is capable of conducting its business to many countries and regions with competitive, safe and reliable products and services to customers all over the world.

The company boasts an extensive portfolio of products, encompassing AC drives, servo systems, and control systems. These products have been extensively deployed across various sectors such as heavy industry, light industry, and high-end equipment. With numerous mature application cases, they offer scenario-based solutions designed to facilitate the digital and intelligent transformation and upgrading of the manufacturing industry. Moreover, the company is in lockstep with the zeitgeist, expanding its reach into burgeoning fields like robotics, new energy, and healthcare. It has developed a suite of innovative products, including hollow cup motors, frameless motors, photovoltaic energy storage inverters, and surgical power systems. These cutting-edge offerings significantly enhance the prosperity and advancement of the industries they serve.

On long-term and persistent R&D and innovation, VEICHI has success-

fully cultivated a series of patented technologies with independent intellectual property rights, and has mastered the core technologies of motor control such as vector control of PMSM, high-frequency pulse injection control, field-weakening control for higher speed, scalar V/F control and vector control etc, and of silicon carbide application, motor parameter tuning and identification, motor control and protection, and motor speed tracking and start-up control. As of June 30, 2024, a total of 221 patents have been granted, including 51 patents for inventions.

Over the course of 19 years, the company has steadily progressed, earning numerous accolades and certifications from national and authoritative bodies. It has been recognized in the third batch of specialized, high-end and innovation-driven SMEs that provide distinctive products or services, and titles of "high-tech enterprise", "Jiangsu Provincial Engineering Technology Research Center", "Jiangsu Provincial Enterprise Technology Center", and "Jiangsu Industrial Internet Development Demonstration Enterprise (Benchmarking Factory Category)".

Moving forward, steadfast in its commitment to the business philosophy of "guided by market demand and driven by technological innovation", VEICHI will fortify its research in key core technologies and enhance product iteration to expand relentlessly across the spectrum of high-performance and quality applications. This strategic focus will enable us to make significant contributions to the evolution of electrical drive and industrial control systems, ensuring that our efforts are directed towards propelling the industry forward with determination and vigor.

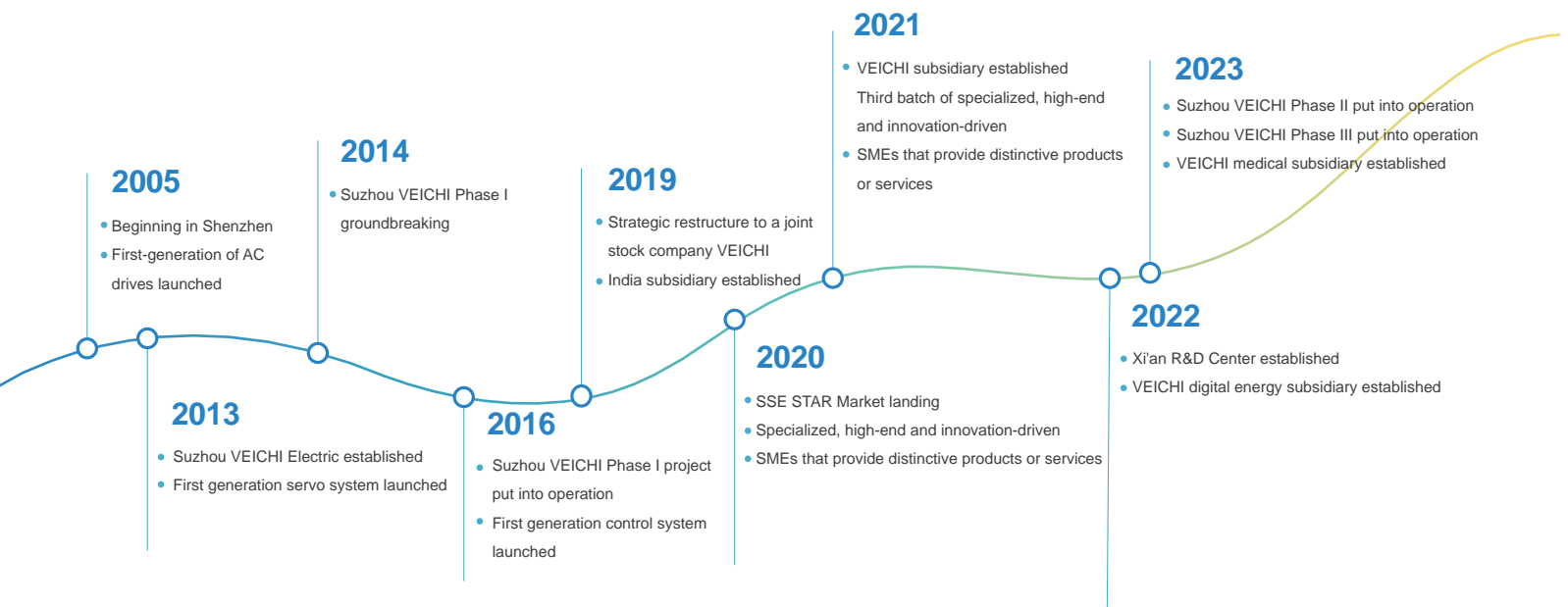

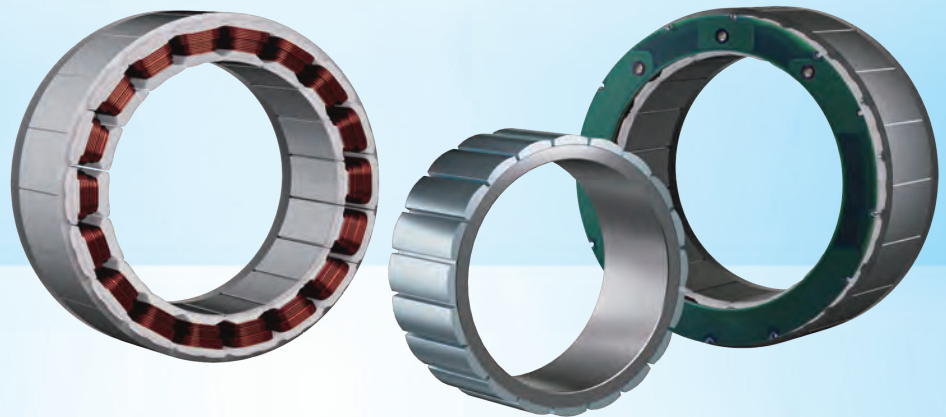

01 Advantages

| | |
|---|-------|
| Leading direct drive performance | 03-04 |
| Safe and reliable structure | 03-04 |
| Multiple configuration options and timely solutions | 03-04 |

02 Product Information

| | |
|-------------------------------|-------|
| Application Scenarios Product | 05-06 |
| Composition | 07-07 |
| Naming Rules | 07-07 |

03 General Specification

| | |
|-------------------------------|-------|
| Mechanical Characteristics | 08-08 |
| Motor Parameters | 09-19 |
| • 3.2.1 FT1-055G15-R1030-□□□ | 09-09 |
| • 3.2.2 FT1-055G25-R1835-□□□ | 10-10 |
| • 3.2.3 FT1-075G15-R2030-□□□ | 11-11 |
| • 3.2.4 FT1-075G23-R3030-□□□ | 12-12 |
| • 3.2.5 FT1-075G30-R3020-□□□ | 13-13 |
| • 3.2.6 FT1-075G30-R4030-□□□ | 14-14 |
| • 3.2.7 FT1-075G42-R7530-□□□ | 15-15 |
| • 3.2.8 FT1-085G33-R5020-□□□ | 16-16 |
| • 3.2.9 FT1-085G38-R6020-□□□ | 17-17 |
| • 3.2.10 FT1-120G36-1R020-□□□ | 18-18 |
| • 3.2.11 FT1-120G47-1R520-□□□ | 19-19 |

04 Motor User Guide

| | |
|--------------------------|-------|
| Installation Guide | 20-21 |
| Installation Precautions | 22-22 |

Advantages



Leading direct driven performance

- 1) Advanced electromagnetic solutions for maximum torque density and smaller motor size
- 2) Smooth and noiseless rotation with less cogging torque



Safe and reliable structure

- 1) Motor winding maximum temperature rating of 155 °C, optional integrated thermistor for safe continuous operation in high standard application
- 2) UL-standard insulation systems for the regulatory requirements
- 3) Material selected in accordance with the RoHS directive
- 4) Compliance with Class C in EN 60034-1:2004 - Rotating electrical machines and the low voltage directive in 2006-95-EC



Multiple configuration options and timely solutions

- 1) Multiple frame sizes available to meet more application requirements
- 2) Optional Hall sensors for standard feedback capabilities
- 3) Basic high and low voltage insulation
- 4) Various standard windings for customization
- 5) Adjustable mechanical interfaces
- 6) Continuous and stable production in digitalized factories for global distribution, and multiple offices in China to provide support and service

Peak Torque
8.7N·m

Peak Speed
4500rpm

Stator OD
85mm

Rotor ID
50mm

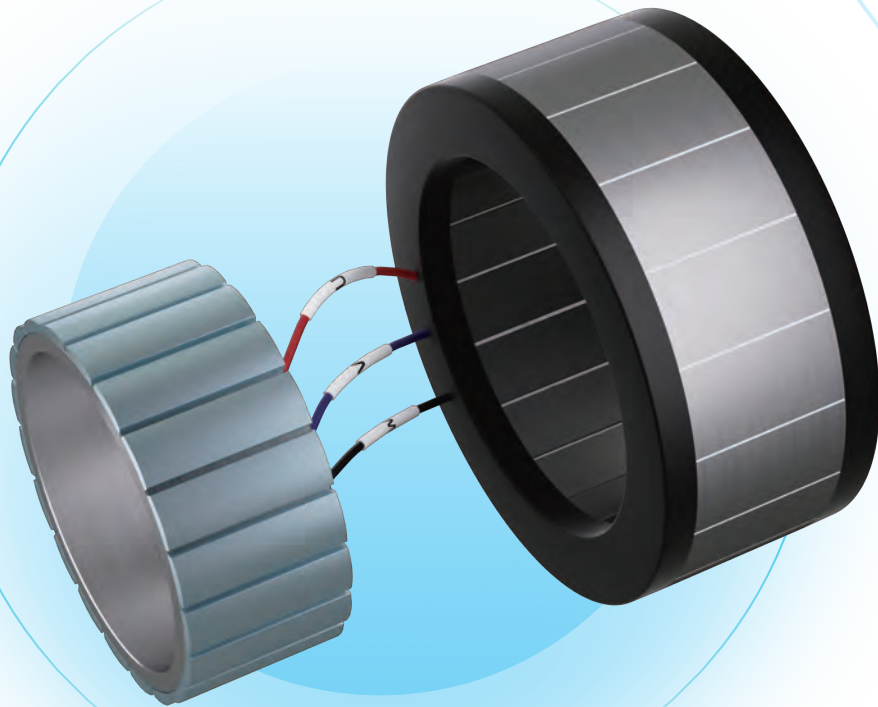

| Product Information

Application Scenarios



01 Collaborative Robots

Lighter frameless motors have irreplaceable advantages in collaborative robotics.

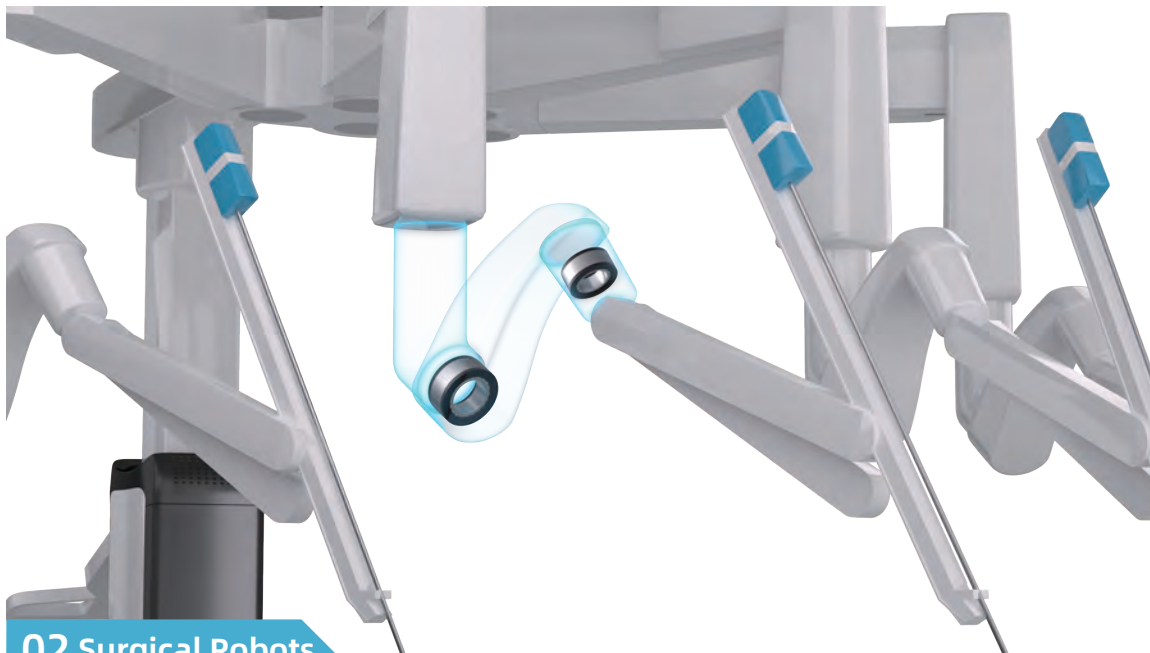

02 Surgical Robots

Surgical robots require a higher degree of precision than other scenarios, and a small frameless volume significantly reduces the height of the robot's joints, allowing for closer movement between the arms and thus a relatively smaller wound size.

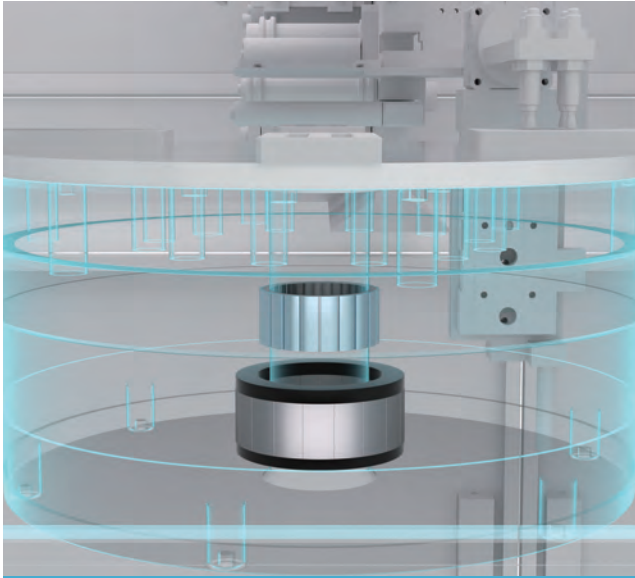

03 Precise Turntable

A frameless motor with optional high-precision bearings and encoders delivers faster positioning of the turntable than traditional direct-drive motors, while the optional axes allow modular modifications and adjustments.



04 Power Assisted Cycle

The compact design helps to reduce the weight of the power-assisted bicycle itself to enhance its maneuverability.



05 Delta Robots

Customized frameless inner/outer diameters facilitate compact robot designs.

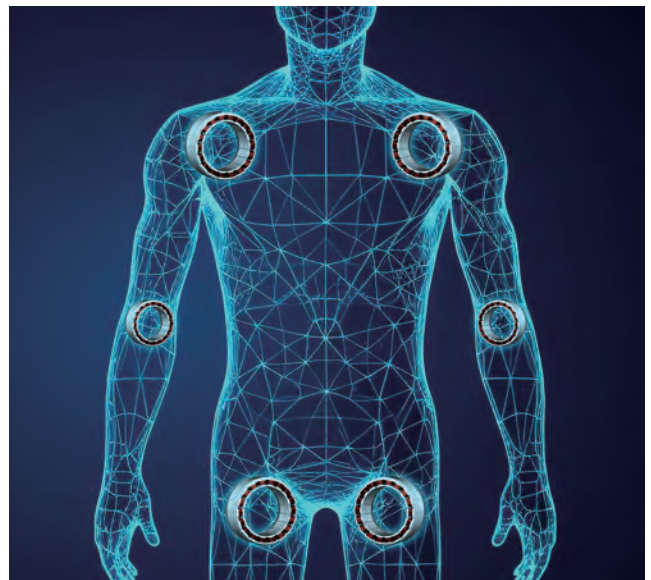

06 Robot Joints

A variety of sizes and joint modules provide new solutions for flexible robot movement.

Product Composition

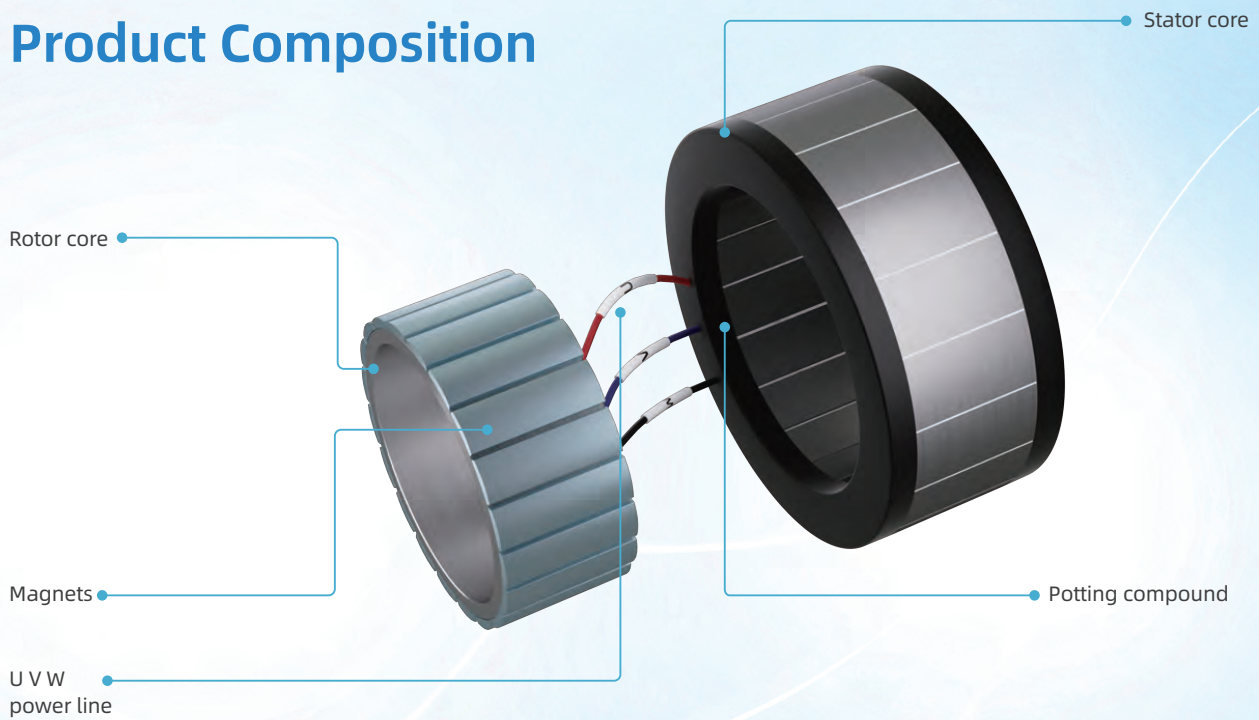

Naming Rules

FT1 - 050 G 18 - R10 30 - N YX

Product Series

FT1: Product series

Stator Outer Diameter

055: 55mm
120: 120mm

Voltage Level

G: Operating voltage 48V

Total Height

18: Overall height not exceeding 18mm
38: Overall height not exceeding 38mm So as other values

Outlet Type and Length

Y: Direct outlet
U: Outlet with adapter
X is the length of the outlet line, 200m by default.
No need to check this when it is not special, check the actual length.

Sensor

N: No optional sensor
D: Hall + temperature sensor optional
W: Temperature sensor optional
H: Hall sensor optional

Rated Speed

Rated speed = Value × 100, e.g.: 30 for 3000rpm, and so as the other values

Rated Power

Rated speed = Value × 1000, R means the decimal point. e.g.: R10 for 100W, 1R5 for 1500W, and so as the other values

Specification

Mechanical Characteristics

| Item | | Description |
|-----------------------|---------------------|---|
| Work mode | | S1(Continuous) |
| Insulation resistance | | 48V DC, >10MΩ |
| Excitation mode | | Permanent magnet |
| Installation method | | Flange |
| Insulation class | | F |
| Insulation voltage | | AC1500V, 1 minute(220V) |
| Protection level | | IP67(except axis extension) |
| FWD operation | | FWD by default in the drive setting Counterclockwise (CCW) when viewed from the axis extension side |
| Environment | Ambient temperature | -20°C~40°C(no freezing) (Use according the derating curve above 40°C) |
| | Working humidity | 20%~ 90%(no condensing) |
| | Installation site | <ul style="list-style-type: none"> Indoor places free of corrosive gas or explosive gas Well-ventilated places with little dust, garbage and humidity Places for easy inspection and cleaning Use normally when the altitude is lower than 1000m, above 1000m, while derate when above 1000m. Refer to "3.3 Derating Characteristics" Places free of intense electric or magnetic fields Places away from heat sources such as furnaces Not applicable to vacuum environments Concentric installation as required |
| | Storage environment | When storing the motor without electricity, observe the following environmental requirements <ul style="list-style-type: none"> Storage temperature -20°C~+60°C(no freezing) Storage humidity 20%~80%RH(no condensing) |

Motor Parameters

FT1-055G15-R1030-□□□

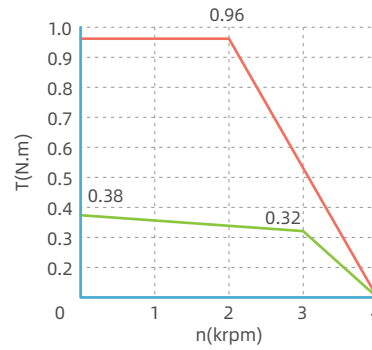
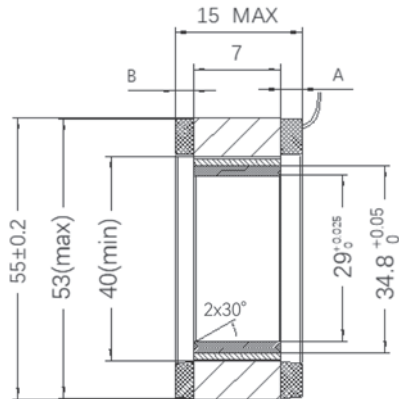

| Motor Size | | Motor Parameters | |
|-------------------------------|------|--|-------|
| Stator OD(mm) | 55 | Rated power(W) | 100 |
| Stator ID(mm) | 40 | Rated voltage(V) | 48 |
| Potting compound OD(mm) | 53 | Rated current(A) | 2.7 |
| Potting height(Outlet) A | < 5 | Max. current(A) | 10.5 |
| Potting height B | < 3 | Stall current(A) | 3.24 |
| Stator height | 15 | Back emf(V) | 9 |
| Stator ID(mm) | 29 | Rated torque(N.m) | 0.32 |
| Stator OD | 34.8 | Max. torque(N.m) | 0.96 |
| Stator core inner height (mm) | 7 | Rated speed(rpm) | 3000 |
| Weight(kg) | | Mechanical time constant τ_m (ms) | 1.83 |
| | | Line resistance(Ohms) | 1.73 |
| | | Line inductance(mh) | 1.8 |
| | | Rotor inertia(kg*cm ²) | 0.085 |
| | | Pole pair No. | 10 |

FT1-055G25-R1835-□□□

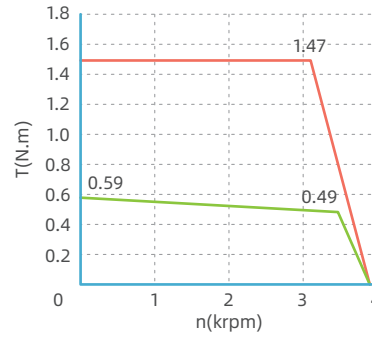
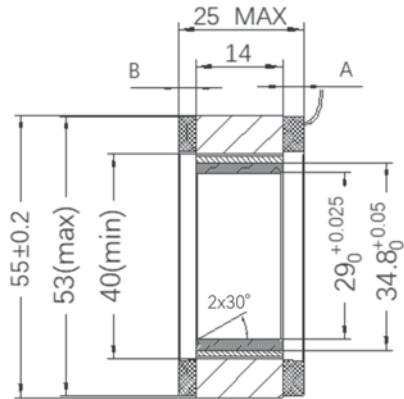

| Motor Size | | Motor Parameters | |
|-------------------------------|------|--|------|
| Stator OD(mm) | 55 | Rated power(W) | 180 |
| Stator ID(mm) | 40 | Rated voltage(V) | 48 |
| Potting compound OD(mm) | 53 | Rated current(A) | 4.9 |
| Potting height(Outlet) A | < 7 | Max. current(A) | 15.7 |
| Potting height B | < 5 | Stall current(A) | 5.8 |
| Stator height | 25 | Back emf(V) | 8.5 |
| Stator ID(mm) | 29 | Rated torque(N.m) | 0.49 |
| Stator OD | 34.8 | Max. torque(N.m) | 1.47 |
| Stator core inner height (mm) | 14 | Rated speed(rpm) | 3500 |
| Weight(kg) | | Mechanical time constant τ _m (ms) | 1.8 |
| | | Line resistance(Ohms) | 0.83 |
| | | Line inductance(mh) | 0.85 |
| | | Rotor inertia(kg*cm ²) | 0.17 |
| | | Pole pair No. | 10 |

FT1-075G15-R2030-□□□

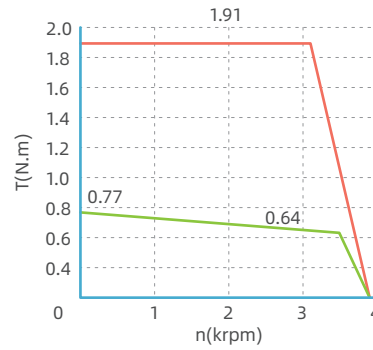
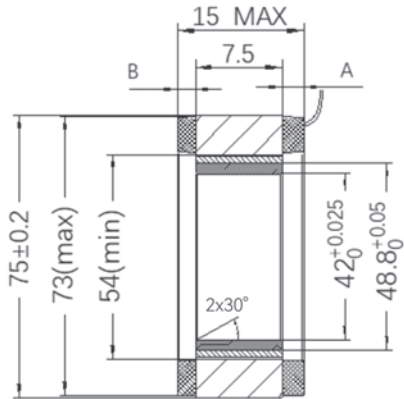

| Motor Size | | Motor Parameters | |
|-------------------------------|------|--|-------|
| Stator OD(mm) | 75 | Rated power(W) | 200 |
| Stator ID(mm) | 54 | Rated voltage(V) | 48 |
| Potting compound OD(mm) | 73 | Rated current(A) | 5.8 |
| Potting height(Outlet A) | < 5 | Max. current(A) | 16.8 |
| Potting height B | < 3 | Stall current(A) | 5.8 |
| Stator height | 15 | Back emf(V) | 8.5 |
| Stator ID(mm) | 42 | Rated torque(N.m) | 0.64 |
| Stator OD | 48.8 | Max. torque(N.m) | 1.91 |
| Stator core inner height (mm) | 7.5 | Rated speed(rpm) | 3000 |
| Weight(kg) | | Mechanical time constant τ_m (ms) | 1.63 |
| | | Line resistance(Ohms) | 0.247 |
| | | Line inductance(mh) | 0.86 |
| | | Rotor inertia(kg*cm ²) | 0.259 |
| | | Pole pair No. | 10 |

FT1-075G23-R3030-□□□

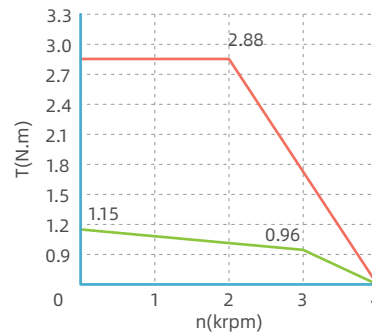
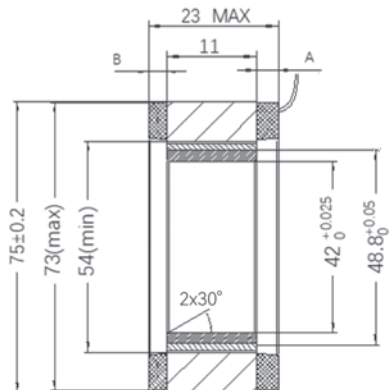

| Motor Size | | Motor Parameters | |
|-------------------------------|------|--|-------|
| Stator OD(mm) | 75 | Rated power(W) | 300 |
| Stator ID(mm) | 54 | Rated voltage(V) | 48 |
| Potting compound OD(mm) | 73 | Rated current(A) | 6 |
| Potting height(Outlet) A | < 7 | Max. current(A) | 18 |
| Potting height B | < 5 | Stall current(A) | 7.2 |
| Stator height | 23 | Back emf(V) | 9 |
| Stator ID(mm) | 42 | Rated torque(N.m) | 0.96 |
| Stator OD | 48.8 | Max. torque(N.m) | 2.88 |
| Stator core inner height (mm) | 11 | Rated speed(rpm) | 3000 |
| Weight(kg) | | Mechanical time constant τ _m (ms) | 1.83 |
| | | Line resistance(Ohms) | 0.175 |
| | | Line inductance(mh) | 0.6 |
| | | Rotor inertia(kg*cm ²) | 0.381 |
| | | Pole pair No. | 10 |

FT1-075G30-R3020-□□□

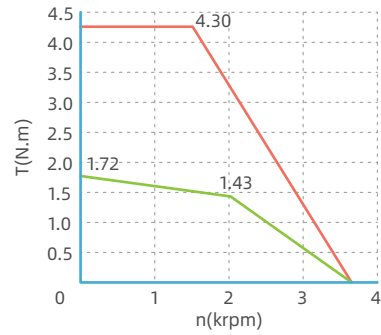
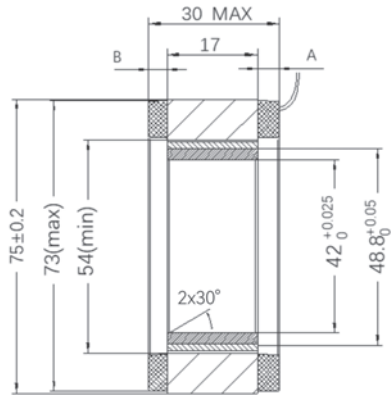

| Motor Size | | Motor Parameters | |
|-------------------------------|------|--|------|
| Stator OD(mm) | 75 | Rated power(W) | 300 |
| Stator ID(mm) | 54 | Rated voltage(V) | 48 |
| Potting compound OD(mm) | 73 | Rated current(A) | 9 |
| Potting height(Outlet) A | < 7 | Max. current(A) | 27 |
| Potting height B | < 5 | Stall current(A) | 10.8 |
| Stator height | 30 | Back emf(V) | 9.6 |
| Stator ID(mm) | 42 | Rated torque(N.m) | 1.43 |
| Stator OD | 48.8 | Max. torque(N.m) | 4.3 |
| Stator core inner height (mm) | 17 | Rated speed(rpm) | 2000 |
| Weight(kg) | | Mechanical time constant τ _m (ms) | 1.56 |
| | | Line resistance(Ohms) | 0.14 |
| | | Line inductance(mh) | 0.49 |
| | | Rotor inertia(kg*cm ²) | 0.59 |
| | | Pole pair No. | 10 |

FT1-075G30-R4030-□□□

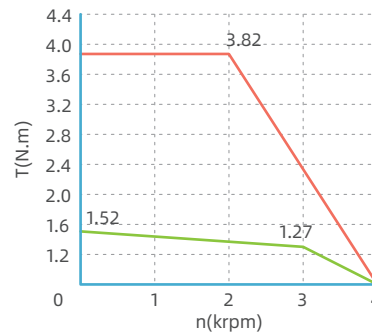
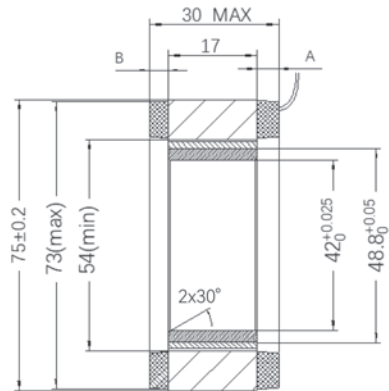

| Motor Size | | Motor Parameters | |
|-------------------------------|------|--|------|
| Stator OD(mm) | 75 | Rated power(W) | 400 |
| Stator ID(mm) | 54 | Rated voltage(V) | 48 |
| Potting compound OD(mm) | 73 | Rated current(A) | 11 |
| Potting height(Outlet) A | < 7 | Max. current(A) | 33 |
| Potting height B | < 5 | Stall current(A) | 13.2 |
| Stator height | 30 | Back emf(V) | 8.5 |
| Stator ID(mm) | 42 | Rated torque(N.m) | 1.27 |
| Stator OD | 48.8 | Max. torque(N.m) | 3.82 |
| Stator core inner height (mm) | 17 | Rated speed(rpm) | 3000 |
| Weight(kg) | | Mechanical time constant τ _m (ms) | 1.80 |
| | | Line resistance(Ohms) | 0.11 |
| | | Line inductance(mh) | 0.38 |
| | | Rotor inertia(kg*cm ²) | 0.59 |
| | | Pole pair No. | 10 |

FT1-075G42-R7530-□□□

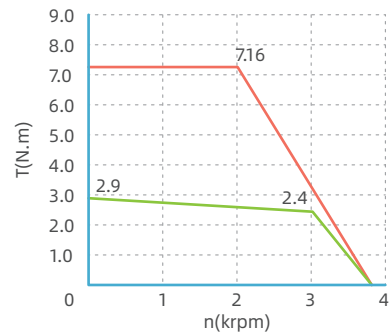
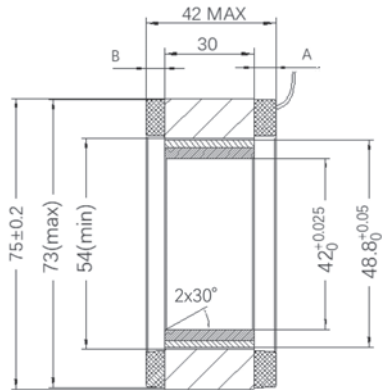

| Motor Size | | Motor Parameters | |
|-------------------------------|------|--|-------|
| Stator OD(mm) | 75 | Rated power(W) | 750 |
| Stator ID(mm) | 54 | Rated voltage(V) | 48 |
| Potting compound OD(mm) | 73 | Rated current(A) | 20.6 |
| Potting height(Outlet) A | < 7 | Max. current(A) | 61.8 |
| Potting height B | < 5 | Stall current(A) | 24.72 |
| Stator height | 42 | Back emf(V) | 8.5 |
| Stator ID(mm) | 42 | Rated torque(N.m) | 2.4 |
| Stator OD | 48.8 | Max. torque(N.m) | 7.16 |
| Stator core inner height (mm) | 30 | Rated speed(rpm) | 3000 |
| Weight(kg) | | Mechanical time constant τ_m (ms) | 1.62 |
| | | Line resistance(Ohms) | 0.06 |
| | | Line inductance(mh) | 0.21 |
| | | Rotor inertia(kg*cm ²) | 1.04 |
| | | Pole pair No. | 10 |

FT1-085G33-R5020-□□□

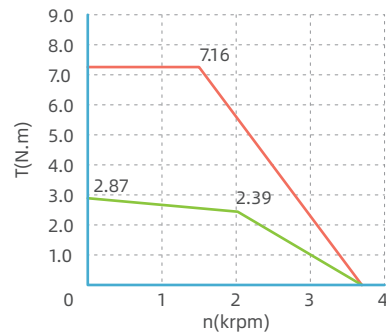
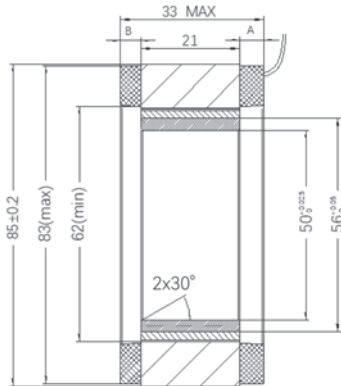

| Motor Size | | Motor Parameters | |
|-------------------------------|-----|--|------|
| Stator OD(mm) | 85 | Rated power(W) | 500 |
| Stator ID(mm) | 62 | Rated voltage(V) | 48 |
| Potting compound OD(mm) | 83 | Rated current(A) | 17.2 |
| Potting height(Outlet) A | < 7 | Max. current(A) | 51.6 |
| Potting height B | < 5 | Stall current(A) | 20.6 |
| Stator height | 33 | Back emf(V) | 10 |
| Stator ID(mm) | 50 | Rated torque(N.m) | 2.39 |
| Stator OD | 56 | Max. torque(N.m) | 7.16 |
| Stator core inner height (mm) | 21 | Rated speed(rpm) | 2000 |
| Weight(kg) | | Mechanical time constant τ _m (ms) | 1.43 |
| | | Line resistance(Ohms) | 0.18 |
| | | Line inductance(mh) | 0.35 |
| | | Rotor inertia(kg*cm ²) | 1.06 |
| | | Pole pair No. | 10 |

FT1-085G38-R6020-□□□

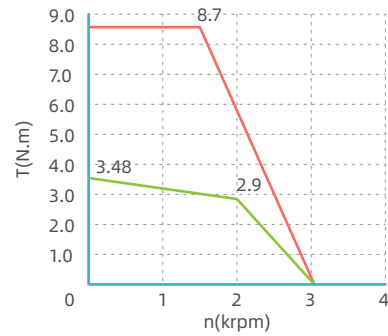
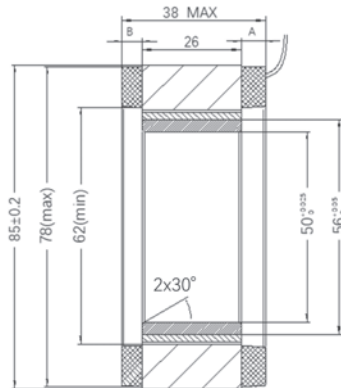

| Motor Size | | Motor Parameters | |
|-------------------------------|------|--|------|
| Stator OD(mm) | 85 | Rated power(W) | 600 |
| Stator ID(mm) | 61.6 | Rated voltage(V) | 48 |
| Potting compound OD(mm) | 59.6 | Rated current(A) | 20 |
| Potting height(Outlet) A | < 7 | Max. current(A) | 60 |
| Potting height B | < 5 | Stall current(A) | 30 |
| Stator height | 38 | Back emf(V) | 9 |
| Stator ID(mm) | 50 | Rated torque(N.m) | 2.9 |
| Stator OD | 56 | Max. torque(N.m) | 8.7 |
| Stator core inner height (mm) | 26 | Rated speed(rpm) | 2000 |
| Weight(kg) | | Mechanical time constant τ_m (ms) | 1.87 |
| | | Line resistance(Ohms) | 0.1 |
| | | Line inductance(mh) | 0.26 |
| | | Rotor inertia(kg*cm ²) | 1.32 |
| | | Pole pair No. | 10 |

FT1-120G36-1R020-□□□

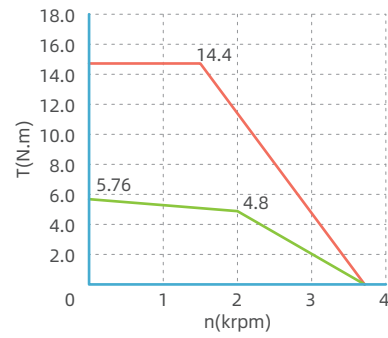
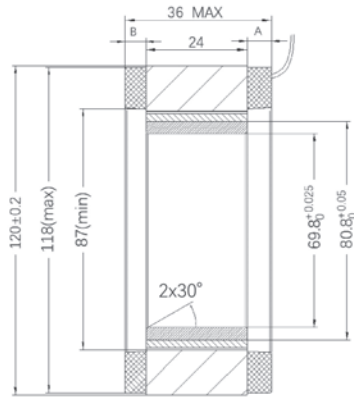

| Motor Size | | Motor Parameters | |
|-------------------------------|------|--|-------|
| Stator OD(mm) | 120 | Rated power(W) | 1000 |
| Stator ID(mm) | 87 | Rated voltage(V) | 48 |
| Potting compound OD(mm) | 118 | Rated current(A) | 26.7 |
| Potting height(Outlet) A | < 7 | Max. current(A) | 80.1 |
| Potting height B | < 5 | Stall current(A) | 32.04 |
| Stator height | 36 | Back emf(V) | 12 |
| Stator ID(mm) | 69.8 | Rated torque(N.m) | 4.8 |
| Stator OD | 80.8 | Max. torque(N.m) | 14.4 |
| Stator core inner height (mm) | 24 | Rated speed(rpm) | 2000 |
| Weight(kg) | | Mechanical time constant τ _m (ms) | 1.67 |
| | | Line resistance(Ohms) | 0.025 |
| | | Line inductance(mh) | 0.26 |
| | | Rotor inertia(kg*cm ²) | 1.46 |
| | | Pole pair No. | 10 |

FT1-120G47-1R520-□□□

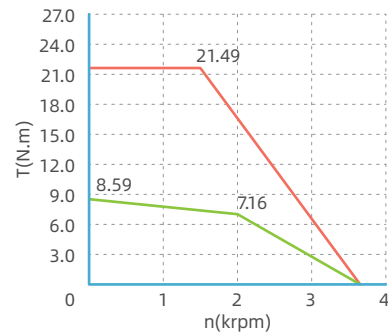
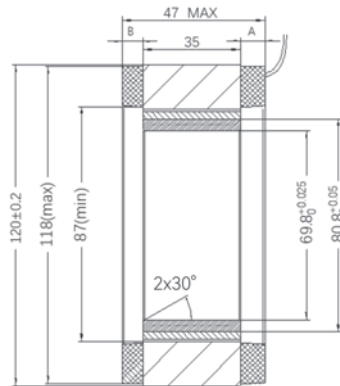

| Motor Size | | Motor Parameters | |
|-------------------------------|------|--|-------|
| Stator OD(mm) | 120 | Rated power(W) | 1500 |
| Stator ID(mm) | 87 | Rated voltage(V) | 48 |
| Potting compound OD(mm) | 118 | Rated current(A) | 40.5 |
| Potting height(Outlet) A | < 7 | Max. current(A) | 121.5 |
| Potting height B | < 5 | Stall current(A) | 48.6 |
| Stator height | 47 | Back emf(V) | 12 |
| Stator ID(mm) | 69.8 | Rated torque(N.m) | 7.16 |
| Stator OD | 80.8 | Max. torque(N.m) | 21.49 |
| Stator core inner height (mm) | 35 | Rated speed(rpm) | 2000 |
| Weight(kg) | | Mechanical time constant τ_m (ms) | 2.1 |
| | | Line resistance(Ohms) | 0.019 |
| | | Line inductance(mh) | 0.19 |
| | | Rotor inertia(kg*cm ²) | 2.13 |
| | | Pole pair No. | 10 |

Motor User Guide

Installation Guide

Stator & Housing

1) Housing material

It is recommended that the stator be assembled in a metal housing by means of bonding, heat sleeve or axial fastening. Installation in the correct structural manner results in optimum thermal conductivity for the entire machine. Aluminum alloy has good thermal conductivity and strength-to-weight ratio, so it is preferred. Carbon steel, cast iron, 400 series stainless steel alloys and other magnetically conductive ferrous metals are not recommended.

2) Stator mounting

1. Adhesive Bonding

For motors with low torque, epoxy adhesives such as Hysol EA934NA, 3M Scotchweld 2214, etc. or anaerobic water such as Loctite638/648 can be used as the bonding agent. In order to ensure the reliability of the bonding, the stator housing should be designed as a cylindrical cavity, and it is recommended that a small step (0.5mm~1mm recommended) be added axially within to position the stator to ensure that the stator is mounted in place. This is shown in the figure below:

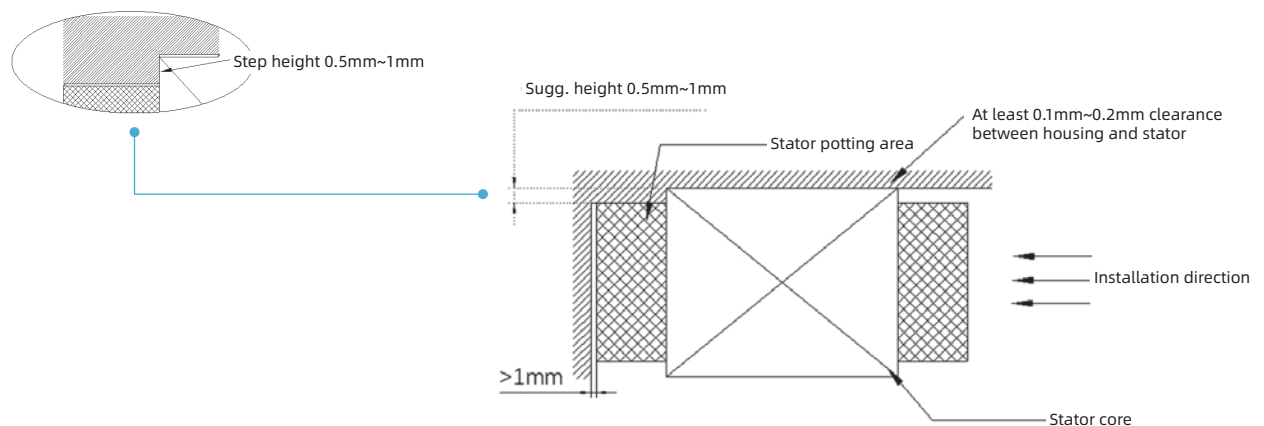

When using the adhesive bonding, it is recommended to add some adhesive grooves on the mounting surface inside the housing to improve the bonding; if the epoxy structural adhesive needs to be heated and cured, note that the heating temperature should not exceed 155°C to avoid damage to the stator core. For different coefficients of expansion [steel laminations vs. aluminum housings], excessive temperatures may cause failures. When used in accordance with the manufacturer's recommendations, these adhesives will provide excellent strength properties over a long period of time. The inside and the outside surfaces of the housing of the stator need to be thoroughly cleaned prior to bonding.

2. Heat Sleeve Assembly

It is recommended that the stator be mounted with the heat sleeve process if without the use of an auxiliary adhesive, since the stator core is a laminated construction and is not suitable for cold pressing. When selecting a heat sleeve, there is an interference fit between the housing and the stator. Specific tolerances should be designed with reference to the coefficients of thermal expansion of the different materials. Please check the required pull-off force for the actual working conditions, and thus to decide whether the assembly of the heat sleeve can be completed at different temperatures.

3. Axial Fastening Assembly

When there is a need to disassemble the motor, or when the output torque is small, the stator can be assembled by axial fastening, but this method is not recommended. When this method is selected, adopt a clearance fit between the stator and the housing, i.e., a sliding assembly, and the stator can be fixed by axial fastening, i.e., by adding new plates. The motor is a moving part that vibrates during operation, which amplifies the risk of loosening of the fasteners, so this method should not be used for mass-produced products.

Note:

Whether it is bonding, hot-setting or axial fastening, it is a type of clearance fit in actual working conditions. A clear coaxial datum should be assigned during the assembly to ensure the coaxiality of the stator and the housing, and positioning fixtures should be prepared to improve the coaxiality.

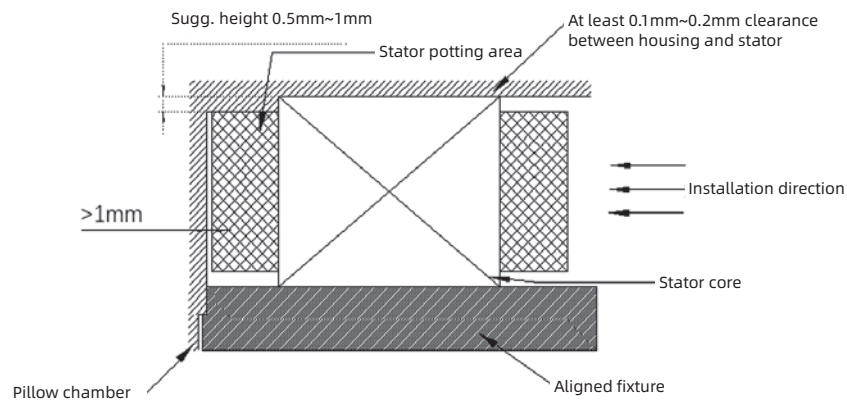

Rotor & Axis

Frameless motors stand out for their rotor assembly, which includes high-performance rare-earth magnets neatly fixed to a metal rotor ring. Common in industrial settings, this rotor ring is usually made from metal and is assembled using one of two methods: cold pressing or adhesive bonding. The exact shaft tolerances are determined by the assembly method used.

To guarantee superior motor performance, adhere to these key assembly principles when constructing the rotor and stator:

1. Align the rotor magnets with the stator core's center to ensure optimal magnetic interaction.
2. If absolute alignment cannot be confirmed, ensure that the magnetic portion fully encompasses the stator core within the maximum size limits.

Installation Precautions

Precautions

- 1) The uninstalled magnetic rotor emits a potent magnetic field. Be mindful of its influence on nearby electronic devices due to strong magnetism.
- 2) Due to the strong magnetic fields that can draw in metallic objects, it is crucial to wear gloves during installation to protect your fingers and palms from potential injuries. Additionally, to prevent damage, keep cell phones, watches, and magnetic data media at a safe distance from the magnetic field.
- 3) The motor stator's metal parts must be properly grounded within the housing for operator safety. Failure to do so may compromise safety.
- 4) When not in use, store the rotor and stator in a dry area to prevent rapid rusting caused by excessive moisture.

Research and Production

R&D and Technology Platform

- Consolidating a dynamic force of top-tier professionals and technical experts in domestic industrial control, our R&D team represents 37.16% of our workforce, with 74.62% of our technical staff boasting bachelor's degrees or higher.
- Guided by philosophy of "Innovate with technology and strive for excellence," VEICHI is deeply customer-centric by providing stable and reliable products and technologies designed to the evolving needs of our clients.
- Investing 10% of our revenue into R&D, VEICHI has crafted advanced labs for EMC, safety, reliability, and performance testing to ensure product quality.
- In-depth cooperation with many famous universities and research institutions in China has been established and "Jiangsu Postdoctoral Innovation Practice Base" and "Jiangsu Postgraduate Workstation" are set up successively.

Intelligent Automation

- Digitally driven from inception to production, VEICHI boasts an annual capacity of 914,600 units with streamlined efficiency.
- 5 imported SMT placement lines, 5 automated coating lines, 4 DIP test lines, a robotic arm-equipped automated line, and 12 production lines are equipped with the latest intelligent manufacturing tools.
- All of the product checks are carried out automatically by the management mode of 3 (tri-inspection system)+ 1 (proportional inspection) during the whole process for standard performance.
- Three major production management system WMS, MES and ERP together ensure that the unique code of each product is traceable in the system to manage product quality.



VEICHI

Suzhou Veichi Electric Co., Ltd

No.1000 Songjia Road, Guoxiang street, Wuzhong
Economic and Technological Development Zone,

Tel: +86-512-6617 1988 Fax: +86-512-6617 3610

Facebook: <https://www.facebook.com/veichigroup>

WhatsApp: +86-138 2881 8903

<https://www.veichi.org/>



Official Website

Version: Apr. 2024

Any contents in this book are subject to change without notice. Veichi Electric Co., Ltd all rights reserved, reproduction in all its forms is strictly prohibited.